



# Trimod<sup>B</sup>Besta

Level measurement A brand of Bachofen AG  
[www.trimodbesta.com](http://www.trimodbesta.com)

# Trimod<sup>B</sup>Besta

## Table of contents

<b>Worldwide in use</b>	Trimod Besta level switches	4	
<b>Experts trust us</b>	Approvals	5	
<b>Quality for your safety</b>	Certificates and test reports	6	
<b>The unique three-modular level switch system</b>	Switch-, flange- and float modules	7	
<b>Mounting combinations</b>	Numerous examples	8	
<b>Various Trimod Besta applications</b>	Application examples	9	
<b>Typical switch combinations to handle most applications</b>	Standard Range electric	10	
	Standard Range pneumatic	14	
	Industrial Range	17	
	Plastic Range	19	
<b>Specifying your own particular Trimod Besta level switch ...</b>	Switch modules electric	20	
	Switch modules explosion-proof	23	
	Switch modules pneumatic	24	
	Flange modules standard	25	
	Flange modules industrial	26	
	Flange modules plastic	29	
	Float modules	30	
	Rod extensions	34	
	<b>... or how we can do it for you</b>	Specification sheet	35
	<b>Accessories which save time, labour and expense</b>	Counterflanges	36
Test actuators		37	
Float chambers		38	
<b>Trimod Besta in hazardous areas</b>	Explosion-proof level switches	40	
<b>Electrical data to assist type selection</b>	Micro- and proximity switches	41	

## Trimod Besta level switches are used worldwide in many industries



### Oil & Gas

Bachofen Ltd. has extensive experience in the offshore industry. Some important features of the Trimod Besta product range for oil & gas applications include stainless steel housings in explosion-proof design, custom-made float chamber design and NACE compliance.



### Shipbuilding

Trimod Besta level switches are specified by the world's major shipyards and owners. Much of Bachofen's product development and design has evolved from experience within the marine industry such as fully submersible housings and captive terminal components. Trimod Besta level switches are registered worldwide and include LRS, DNV, ABS, BV, RINA, RMRS and ClassNK shipping approvals.



### Power Generation

Extreme reliability is vital in some of the applications in power plants. Shock and vibration resistant Trimod Besta level switches are used for critical turbine trip duties on HP/LP heater plants.



### Chemical & Petrochemical Industry

In the chemical- and petrochemical industry Trimod Besta's modular design can solve many special application problems which may require high pressure, high temperature and corrosion resistant components. For measurement and control of highly aggressive or high purity media we offer a complete program of plastic switches.



### Plant Engineering

Trimod Besta offers OEMs and plant manufacturers countless level switches from the standard and industrial series. Customised solutions with various tests and approvals are available from small quantities.



### Water Management

For water management Bachofen Ltd. provides standard level switches together with accessories, such as counterflanges and test actuators. Various special executions can be used in highly contaminated media or in toilet systems.

## Experts trust us

Trimod Besta level switches have been examined and approved by the most important and internationally recognized organisations. Numerous approvals together with periodic audits warrant continuous quality control throughout the production process. The list of approvals for Trimod Besta level switches and accessories is growing continuously. Contact us, for up to date information or go to [www.trimodbesta.com](http://www.trimodbesta.com) for current certificates.



ClassNK

<b>American Bureau of Shipping</b>	<b>ABS</b>
<b>Bureau Veritas</b>	<b>BV</b>
<b>Det Norske Veritas</b>	<b>DNV</b>
<b>Lloyds Register of Shipping</b>	<b>LRS</b>
<b>Registro Italiano Navale</b>	<b>RINA</b>
<b>Russian Maritime Register of Shipping</b>	<b>RMRS</b>
<b>Nippon Kaiji Kyōkai</b>	<b>ClassNK</b>
<b>exida Certification S.A. Safety Integrity Level</b>	<b>SIL</b> IEC 61508/61511



<b>Bureau Veritas Consumer Products Services Germany GmbH</b>	EPS 12 ATEX 1430 X	Ex eb db IIC T6...T5 Ga/Gb (Z...8) Ex ia IIC T6 Ga/Gb (B...8) Ex ia IIC T6...T1 Ga/Gb (I...8)
	IECEX EPS 15.0038 X	Ex eb db IIC T6...T5 Ga/Gb (Z...5) Ex ia IIC T6 Ga/Gb (B...5) Ex ia IIC T6...T1 Ga/Gb (I...5)
	EPS 22 UKEX 1261 X	Ex eb db IIC T6...T5 Ga/Gb (Z...7) Ex ia IIC T6 Ga/Gb (B...7) Ex ia IIC T6...T1 Ga/Gb (I...7)

**EAC** EA3C N RU Д-CH.АД53.В.02795/18

**Swiss Safety Center AG** PED-Z-COS.EP.5515489 Kat. IV nach DGRL (PED)

# Quality for your safety

Quality control is a cornerstone of our management philosophy and therefore, we have integrated the quality system according to ISO 9001 certified by SWISO GmbH Switzerland. Thus, quality control to us is not only a strong sales argument, but also an obligation.



The following official Bachofen certificates and test reports are available on request:



**Certificate of compliance with order 2.1 acc. to EN 10204**  
Confirmation that the products meet the requirements of the order.



**Test report 2.2 acc. to EN 10204**  
For flange and float materials of the level switches, counterflanges and test actuators.



**Inspection certificate 3.1 acc. to EN 10204**  
For flange materials of the level switches, counterflanges and the intermediate part of the test actuators.

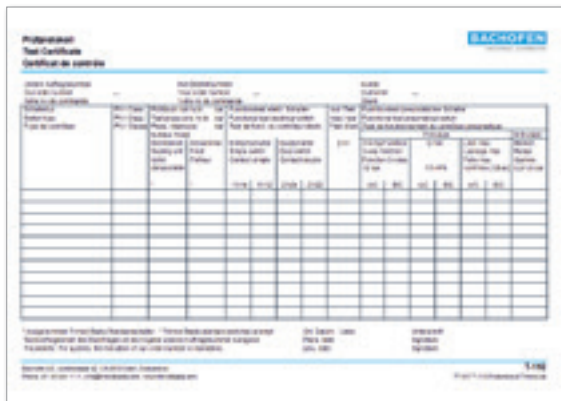

**Test certificate - function test**  
For Trimod Besta level switches (electr. function test, pneumatic function test etc.)

## The unique three-modular level switch system



### What you need ...

Trimod Besta's modular design is a unique deviation from conventional level switch construction. This modular system allows individual and numerous combinations of float, flange and switch modules to suit your specific requirements. Switch modules are available with electric, electronic or pneumatic output signals. Switch housings are standard to IP65 enclosure, but depending on environmental conditions IP66, IP67 or IP68 must be chosen. For hazardous areas explosion-proof switch modules can be used.



### ... is quickly installed ...

Trimod Besta flange modules are available in various standards. The flanges of Industrial and Plastic Range are manufactured according to international standards such as EN/DIN, ANSI or JIS. The benefit of the hinged cover, the captive screws and the selflifting terminal clamps is an easy installation. For convenience of wiring, the connection diagram is shown on the inside of the hinged lid. The interchangeability of the single modules allows high flexibility regarding maintenance or changing application requirements.



### ... and lasts forever.

So far, hundreds of thousands of Trimod Besta level switches are on duty world-wide. The float movement caused by the rise and fall of the liquid level is transmitted by two repelling, permanent AlNiCo magnets. The sturdy design and the double snap effect as a result of the magnetic repulsion and the snap action of the microswitch guarantee a virtually unlimited lifetime. The float modules, like all wetted parts, are made of stainless steel, Hastelloy C or high quality plastics. A wide range of floats is available to suit various viscosity-, temperature- and pressure ranges for almost any process condition.



## With modular compatibility all options are open

### Side mount combinations

- 01 with microswitch or proximity switch, also available in explosion proof version
- 02 pneumatic switch module with ON/OFF or proportional output
- 03 with enclosure IP68 for underwater installation
- 04 with heat exchanger for very high or very low operating temperatures
- 05 square standard flange made of CrNiMo, 92 mm pitch circle diameter
- 06 industrial flange acc. to EN/DIN, ANSI and JIS made of PP and PTFE
- 07 industrial flange acc. to EN/DIN, ANSI and JIS made of CrNiMo and Hastelloy
- 08 with fixed operating differential
- 09 with rod extension for longer operating differentials
- 10 rod extension for switch point correction
- 11 with protective bellows for media with solids content
- 12 with adjustable operating differential for pump control
- 13 plastic version for aggressive media
- 14 for separation layer monitoring of two media with different densities
- 15 for vertical mounting
- 16 for vertical mounting with rod extension

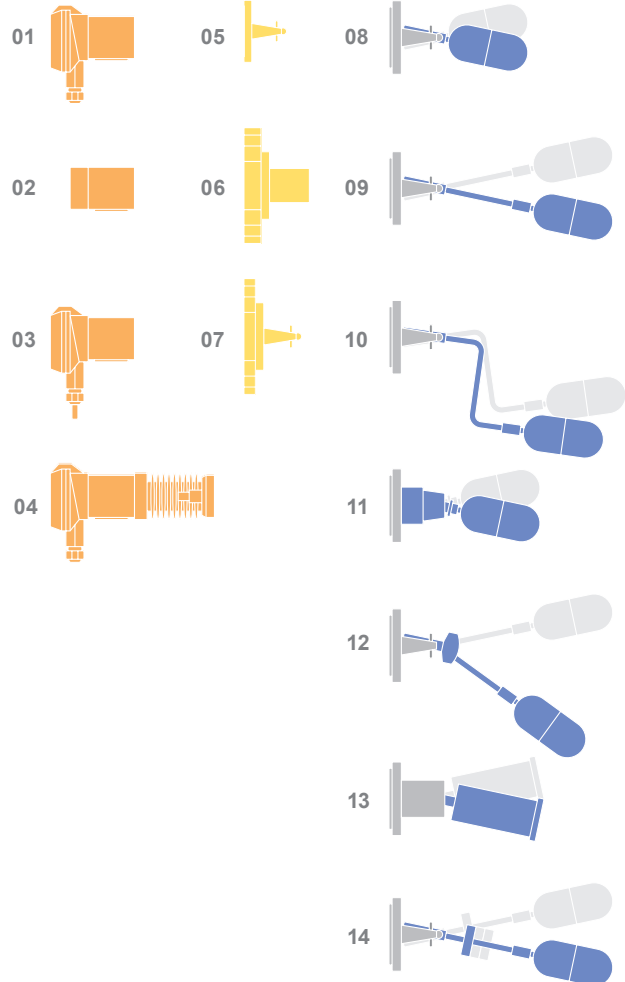

### Top mount combinations

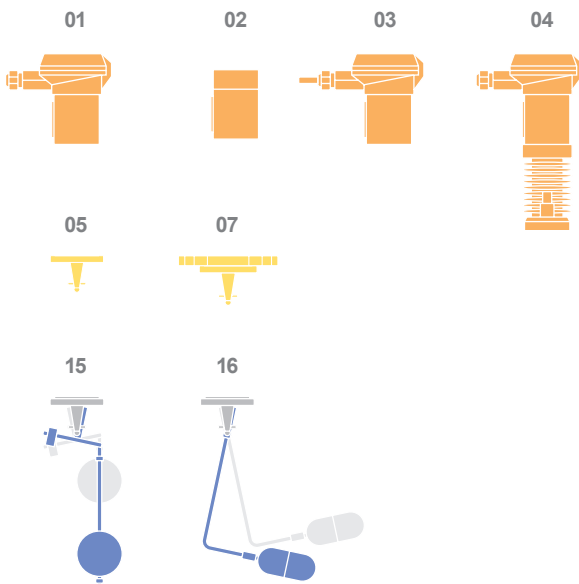



# Application examples

## Alarm, limit and control functions with Trimod Besta

Max/min limits

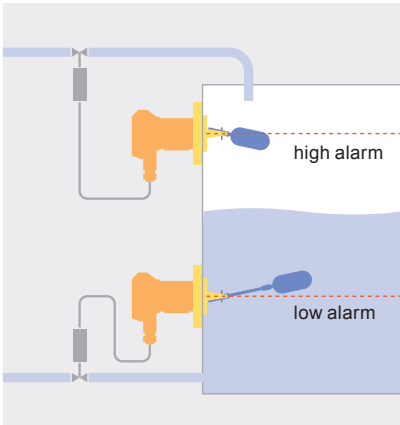

Pneumatic control

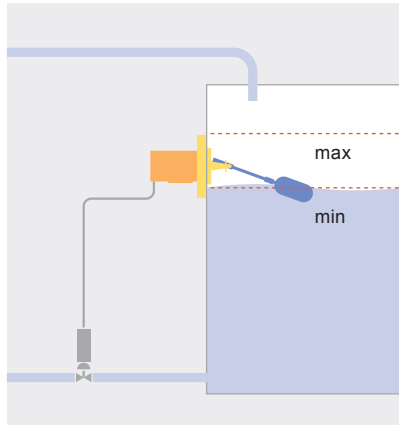

Pump and valve control

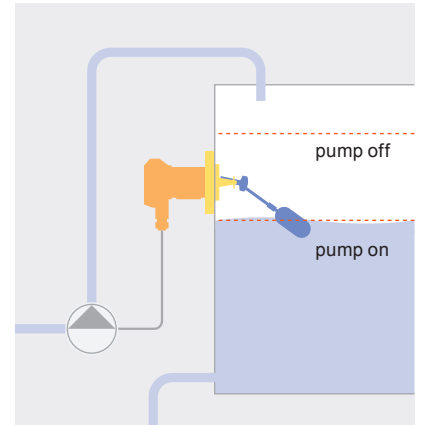

Pump and valve control

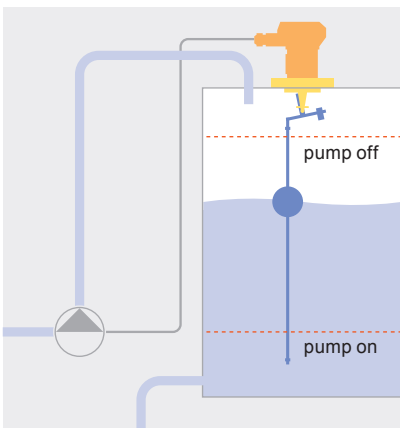

Separation layer control

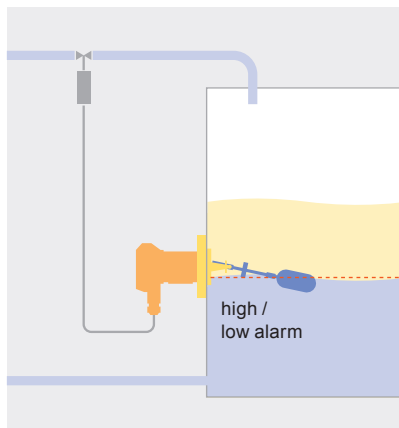

External level control

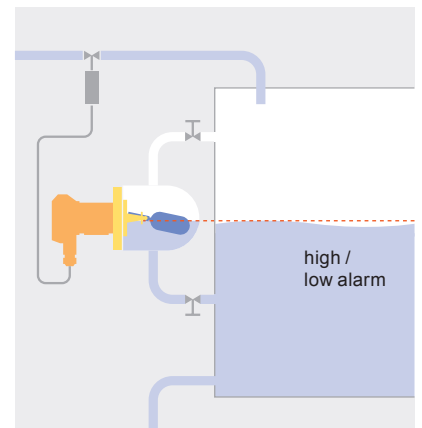

## Typical Standard Range switches to handle the majority of applications

The characteristic of a Trimod Besta level switch of the Standard Range is the square flange in stainless steel with bolt holes on a 92 mm PCD and a nominal pressure rating of PN 25.

The following pages show the level switches which are most commonly used. However, countless more combinations of types are possible. Detailed information can be found on all the modules available with the possible combinations on pages 20 to 34. For accessories, such as test actuators, counterflanges and float chambers see pages 36 to 39.

**Typical applications:**  
shipbuilding, refrigeration, food industry, drinking water supply, water management etc.

### Type A 01 04 – For general purpose

Nominal pressure	PN 25 max. 25 bar up to 300°C
Operating temperature	0 to 300°C
Ambient temperature	0 to 70°C
Density of liquid	min. 0.7 kg/dm <sup>3</sup>
Operating differential	fixed 12 mm
Rod extensions	see page 34
Wetside material	Stainless steel (CrNiMo)
Flange material	Stainless steel (CrNiMo)
Housing material	Sea water resistant die cast aluminium
Flange dimensions	square 92 x 92 mm, PCD 92 mm
Counterflange	see page 36
Switch element	Microswitch SPDT with silver contacts
Switch rating	250 VAC, 5 A 30 VDC, 5 A
Enclosure	IP65
Weight	approx. 1.8 kg
Safety Integrity Level (SIL)	SIL 1 (Type AA 01 04: SIL 2)

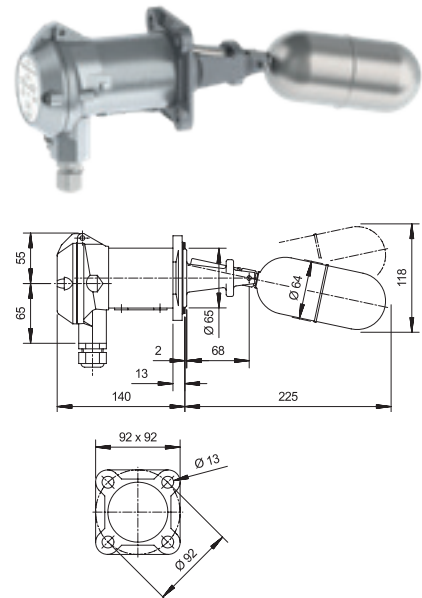

### Type A 01 041 – Low cost solution

This type is the same as the A 01 04 but there is no possibility for mounting a rod extension.

### Type A 01 01 – For installation in limited space

The overall length of this type is 194 instead of 225 mm. Minimum liquid density: 0.8 kg/dm<sup>3</sup>. All other data as type A 01 04.

### Type 5A 01 04 – For corrosive environments

As type A 01 04 except that the complete switch housing (excluding the cable gland), is manufactured in stainless steel (CrNiMo) and is therefore highly corrosion resistant. Weight approx. 2.7 kg.

### Type A 01 07 – For low density fluids

This level switch can be used for liquids with densities as low as 0.5 kg/dm<sup>3</sup>. All other technical data as type A 01 04. Weight approx. 2 kg.



**Type A 01 051 to A 01 054 – For contaminated or crystallizing media.**

Bellows to prevent jamming of the float mechanism.

Bellow materials	A 01 051	Perbunan/Buna
	A 01 052	Silicon
	A 01 053	FPM
	A 01 054	PTFE
Operating temperatures	A 01 051	0 to 120°C
	A 01 052	0 to 200°C
	A 01 053	10 to 200°C
	A 01 054	0 to 250°C
Mounting length	253 mm	
Weight	approx. 2 kg	
Density of liquid	min. 0.75 kg/dm <sup>3</sup>	
Safety Integrity Level (SIL)	SIL 1 (Types AA 01 051 – AA 01 054: SIL 2)	

All other technical data as type A 01 04

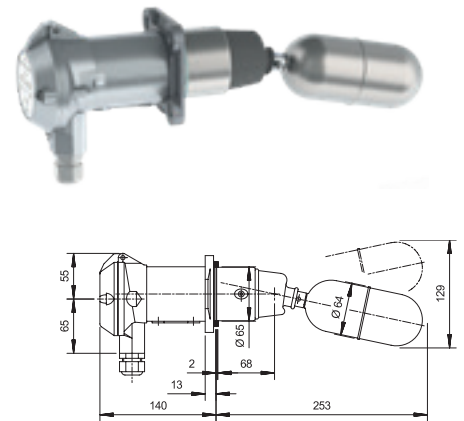
**Type U3A 01 04 to U11A 01 04 – For submersible applications**

Operating temperature	-30 to 80°C	
Ambient temperature	-30 to 80°C	
Housing material	Sea water resistant die cast aluminium	
Enclosure	IP68	
	switch housing is pressure tight up to 100 meters WC (Water column)	
Length of encapsulated cable	U3A 01 04	3 m
	U5A 01 04	5 m
	U11A 01 04	11 m
Weight	U3A 01 04	approx. 2.5 kg
	U5A 01 04	approx. 2.8 kg
	U11A 01 04	approx. 4 kg
Safety Integrity Level (SIL)	SIL 1 (Types U3AA 01 04 – U11AA 01 04: SIL 2)	

All other technical data as type A 01 04

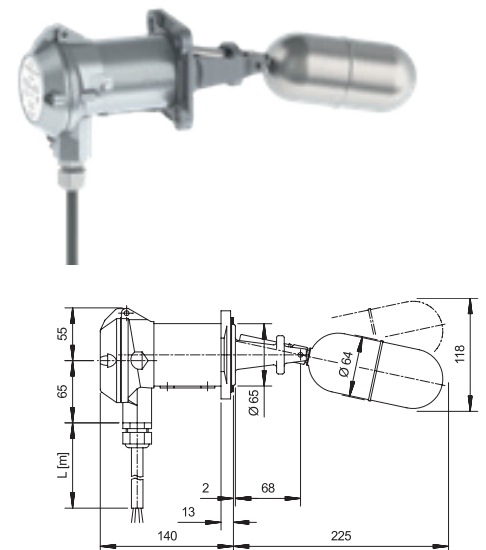
**Type A 01 08T1 – For interface application**

Density of heavier liquids	min. 0.8 kg/dm <sup>3</sup>	
Difference in density	min. 0.22 kg/dm <sup>3</sup>	
Operating differential	approx. 20 mm	
Rod length	100 mm	
Weight	approx. 2.4 kg	
Safety Integrity Level (SIL)	SIL 1 (Type AA 01 08T1: SIL2)	

All other technical data as type A 01 04

The position of the weight on the rod extension is calculated in reference to the densities of the media and is factory preset.

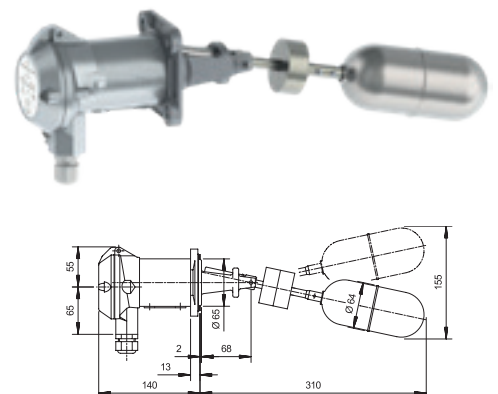

### Type A 01 090 to A 01 095 – For adjustable operating differential

These level switches are mainly used for two-point operation, for example pump control.

Nominal pressure	PN 25, max. 25 bar up to 300°C
Operating temperature	0 to 300°C
Ambient temperature	0 to 70°C
Density of liquid	min. 0.75 kg/dm <sup>3</sup> (A 01 095: min. 0.9 kg/dm <sup>3</sup> )
Operating differential S	see table
Wetside material	Stainless steel (CrNiMo)
Flange material	Stainless steel (CrNiMo)
Housing material	Sea water resistant die cast aluminium
Flange dimensions	square 92 x 92 mm, PCD 92 mm
Counterflange	see page 36
Switch element	Microswitch SPDT with silver contacts
Switch rating	250 VAC, 5 A 30 VDC, 5 A
Enclosure	IP65
Weight	approx. 2 kg
Safety Integrity Level (SIL)	SIL 1 (Types AA 01 090 – AA 01 095: SIL 2)

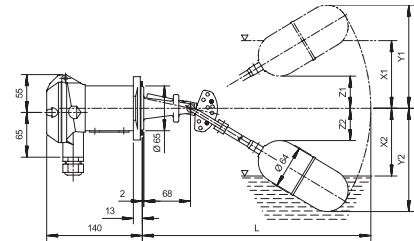

### Adjustment of switching differential

The switching differential can be set by inserting pegs in holes 1 to 9 of the adjustment block (see drawing). The resulting differentials, the positions of the switching points and the float travel can be seen in the table below. The values are in mm and are referenced to water at 20°C and density of 1.0 kg/dm<sup>3</sup>.

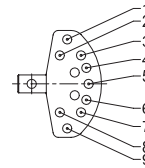

Type L	A 01 090 278 mm					A 01 091 361 mm					A 01 092 461 mm					A 01 093 561 mm					A 01 095 246 mm				
Pos.	X1	X2	Diff. S	Y1 (Z2)	Y2 (Z1)	X1	X2	Diff. S	Y1 (Z2)	Y2 (Z1)	X1	X2	Diff. S	Y1 (Z2)	Y2 (Z1)	X1	X2	Diff. S	Y1 (Z2)	Y2 (Z1)	X1	X2	Diff. S	Y1 (Z2)	Y2 (Z1)
1-4	+108	+60	48	175	(10)	+157	+85	72	238	(20)	+230	+125	105	315	(50)	+292	+160	132	395	(75)	+100	+55	45	147	(10)
1-5	+108	+15	93	175	35	+157	+25	132	238	37	+230	+39	191	315	39	+292	+48	244	395	42	+100	+18	82	147	35
1-6	+108	-25	133	175	85	+157	-37	194	238	105	+230	-51	281	315	135	+292	-65	357	395	165	+100	-18	118	147	74
1-7	+108	-52	160	175	125	+157	-90	247	238	165	+230	-124	354	315	215	+292	-160	452	395	265	+100	-46	146	147	115
1-8	+108	-80	188	175	153	+157	-128	285	238	206	+230	-171	401	315	275	+292	-215	507	395	345	+100	-70	170	147	128
1-9	+108	-110	218	175	175	+157	-160	317	238	238	+230	-212	442	315	315	+292	-265	557	395	395	+100	-90	190	147	147
2-5	+98	+15	83	153	35	+122	+25	97	206	37	+181	+39	142	275	39	+230	+48	182	345	42	+79	+18	61	128	35
2-6	+98	-25	123	153	85	+122	-37	159	206	105	+181	-51	232	275	135	+230	-65	295	345	165	+79	-18	97	128	74
2-7	+98	-52	150	153	125	+122	-90	212	206	165	+181	-124	305	275	215	+230	-160	390	345	265	+79	-46	125	128	115
2-8	+98	-80	178	153	153	+122	-128	250	206	206	+181	-171	352	275	275	+230	-215	445	345	345	+79	-70	149	128	128
2-9	+98	-110	208	153	175	+122	-160	282	206	238	+181	-212	393	275	315	+230	-265	495	345	395	+79	-90	169	128	147
3-5	+58	+15	43	125	35	+81	+25	56	165	37	+122	+39	83	215	39	+145	+48	97	265	42	+52	+18	34	115	35
3-6	+58	-25	83	125	85	+81	-37	118	165	105	+122	-51	173	215	135	+145	-65	210	265	165	+52	-18	70	115	74
3-7	+58	-52	110	125	125	+81	-90	171	165	165	+122	-124	246	215	215	+145	-160	305	265	265	+52	-46	98	115	115
3-8	+58	-80	138	125	153	+81	-128	209	165	206	+122	-171	293	215	275	+145	-215	360	265	345	+52	-70	122	115	128
3-9	+58	-110	168	125	175	+81	-160	241	165	238	+122	-212	334	215	315	+145	-265	410	265	395	+52	-90	142	115	147
4-6	+25	-25	50	85	85	+31	-37	68	105	105	+48	-51	99	135	135	+63	-65	128	165	165	+23	-18	41	74	74
4-7	+25	-52	77	85	125	+31	-90	121	105	165	+48	-124	172	135	215	+63	-160	223	165	265	+23	-46	69	74	115
4-8	+25	-80	105	85	153	+31	-128	159	105	206	+48	-171	219	135	275	+63	-215	278	165	345	+23	-70	93	74	128
4-9	+25	-110	135	85	175	+31	-160	191	105	238	+48	-212	260	135	315	+63	-265	328	165	395	+23	-90	113	74	147
5-7	-15	-52	37	35	125	-33	-90	57	37	165	-40	-124	84	39	215	-50	-160	110	42	265	-12	-46	34	35	115
5-8	-15	-80	65	35	153	-33	-128	95	37	206	-40	-171	131	39	275	-50	-215	165	42	345	-12	-70	58	35	128
5-9	-15	-110	95	35	175	-33	-160	127	37	238	-40	-212	172	39	315	-50	-265	215	42	395	-12	-90	78	35	147
6-9	-55	-110	55	(10)	175	-80	-160	80	(20)	238	-105	-212	107	(50)	315	-135	-265	130	(75)	395	-45	-90	45	(10)	147

**Type A 01 140 to A 01 141 – For vertical mounting**

Nominal pressure	PN 16, max. 16 bar up to 300°C
Operating temperature	0 to 300°C
Ambient temperature	0 to 70°C
Density of liquid	Pump control: min. 0.45 kg/dm <sup>3</sup> Alarm: min. 0.30 kg/dm <sup>3</sup>
Operating differential S	A 01 140: 12 to 1340 mm A 01 141: 12 to 2840 mm
Wetside material	Stainless steel (CrNiMo)
Flange material	Stainless steel (CrNiMo)
Housing material	Sea water resistant die cast aluminium
Flange dimensions	square 92 x 92 mm, PCD 92 mm
Counterflange	see page 36
Switch element	Microswitch SPDT with silver contacts
Switch rating	250 VAC, 5A 30 VDC, 5A
Enclosure	IP65
Weight	A 01 140: approx. 2.5 kg A 01 141: approx. 2.7 kg
Safety Integrity Level (SIL)	SIL 1 (Types AA 01 140 – AA 01 141: SIL 2)

**Setting the switching differential****1. For pump control (two switch points):**

The required differential is set by fixing the two stop collars in the appropriate positions on the rod. The counterweight is adjusted to compensate for the rod weight (without float), until the cross arm is balanced. The float slides up and down the rod with the liquid level and actuates the switch at the set position of the stop collars. The switch remains latched between the two positions, which are for applications such as pump control where the contactor coil would need to remain energised throughout the pumping cycle.

**2. For alarm duty (one switch point):**

Only the lower collar is fixed on the rod (below the float). Within the limit of the rod length, the height of the alarm point can be chosen as required. The counterweight has to be set to outweigh the rod (without float). The alarm switching differential is 12 mm, fixed.

**Installation**

Over open tanks or sumps on a bracket. On closed tanks on the manhole cover with float mounted from the inside. In the absence of a manhole, i.e. the float cannot be mounted from the inside, an intermediate flange of at least DN 125/5" should be used. If turbulence occurs, the rod should be guided loosely at the lower end. For counterweight setting, refer to data sheet LTDS02EN.

**Type U3A 01 140 to 141 – For vertical submersible mounting**

Operating temperature	-30 to 80°C
Ambient temperature	-30 to 80°C
Enclosure	IP68 switch housing is pressure proof up to 100 meters WC (Water column)
Length of cast-in cable	3 m
Weight	U3A 01 140 approx. 3.2 kg U3A 01 141 approx. 3.4 kg
Safety Integrity Level (SIL)	SIL 1 (Types U3AA 01 140 – U3AA 01 141: SIL 2)

All other technical data as described above

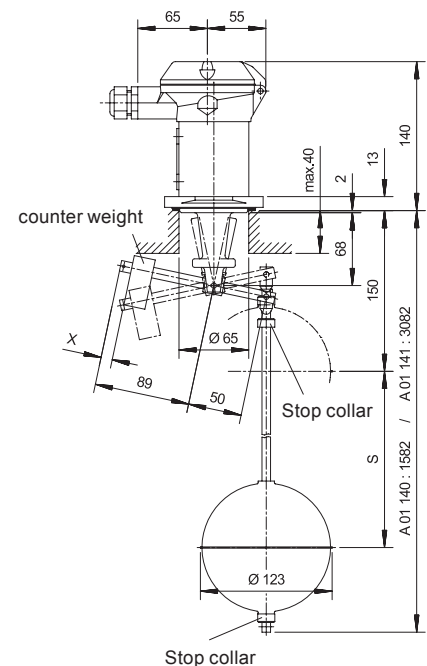

### Type P 01 04 – For pneumatic control applications

Equipped with a directly controlled 3/2 way valve (ON/OFF) for control air of 0 to 10 bar. Operation with other non-corrosive gases or fluids is possible.

Nominal pressure	PN 25, max. 25 bar up to 250°C
Operating temperature	1 to 250°C
Ambient temperature	1 to 80°C
Density of liquid	min. 0.7 kg/dm <sup>3</sup>
Operating differential	fixed 12 mm
Rod extensions	see page 34
Control connections	G 1/8" (BSPP) inside thread
Max. control pressure	10 bar
Internal orifice	1.5 mm
Kv Factor	1
Internal leakage rate at 10 bar	max. 1 cm <sup>3</sup> /min
Air flow	90 NI/min at 6 bar
Pressure drop	1 bar
Wetside material	Stainless steel (CrNiMo)
Flange material	Stainless steel (CrNiMo)
Housing material	Sea water resistant die cast aluminium
Flange dimensions	square 92 x 92 mm, PCD 92 mm
Counterflange	see page 36
Weight	approx. 1.7 kg
Air quality	class 4, acc. to ISO 8573-1 (max. particle size 15 µm, max. particle density 8 mg/m <sup>3</sup> )

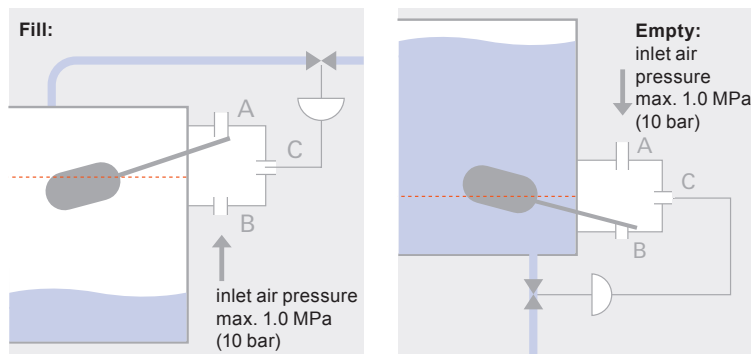
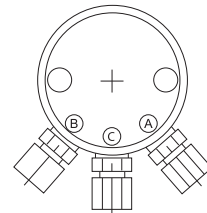
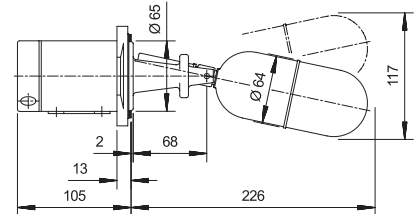

The air supply to the 3/2 way valve may be connected to either A or B, according to whether filling or emptying operation is desired or whether the actuator is normally closed or open when pressurized. E.g. pressure can be applied through A to C and exhausted from C through B, alternatively pressure can be applied through B to C and exhausted from C through A.

**Type 5P 01 04 – For critical environments or high temperatures. All parts stainless steel.** As P 01 04, but switch housing also in stainless steel (CrNiMo) and therefore, highly corrosion resistant and suitable for temperatures up to 300°C. Weight approximately 2.2 kg.

**Type PV 01 04 – For moist control air.** As P 01 04, but with drain valve for condensate removal.

**Type FP 01 04 – For hazardous applications.** As P 01 04, but functionally tested. With declaration of conformity for use in explosion proof areas.

**Type FPV 01 04 – For moist control air in hazardous applications.** As FP 01 04, but with drain valve for condensate removal. With declaration of conformity for use in explosion proof areas.



**Type M 01 04 – For pneumatic proportional control applications**

Equipped with a pneumatic control valve which converts the supply pressure of 1.4 bar to an output signal of 0.2 to 1 bar (Option: 7 to 15 psi), proportional to changes in the liquid level.

Nominal pressure	PN 25, max. 25 bar up to 250°C
Operating temperature	1 to 250°C
Ambient temperature	1 to 80°C
Density of liquid	min. 0.7 kg/dm <sup>3</sup>
Control range	see table below
Control connections	G 1/8" (BSPF) inside thread
Control pressure	1.4 bar
Output signal	0.2 to 1 bar
Linearity	±5% (of full scale output)
Air flow	3.5 to 6.0 NI/min. (can be increased by using external booster valve)
Air consumption	max. 0.4 Nm <sup>3</sup> /h
Wetside material	Stainless steel (CrNiMo)
Flange material	Stainless steel (CrNiMo)
Housing material	Sea water resistant die cast aluminium
Flange dimensions	square 92 x 92 mm, PCD 92 mm
Counterflange	see page 36
Weight	approx. 1.7 kg
Air quality	class 3, acc. to ISO 8573-1 (max. particle size 5 µm, max. particle density 5 mg/m <sup>3</sup> )

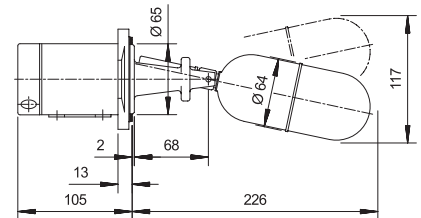

**For operation at higher control pressure up to max. 10 bar**

Control pressure in bar	Output signal in bar min.	Output signal in bar max.	Control range P max / P min
2	0.25	1.5	6
4	0.6	3.1	5.17
6	1.1	4.8	4.36
8	1.8	6.5	3.61
10	2.5	8.3	3.32

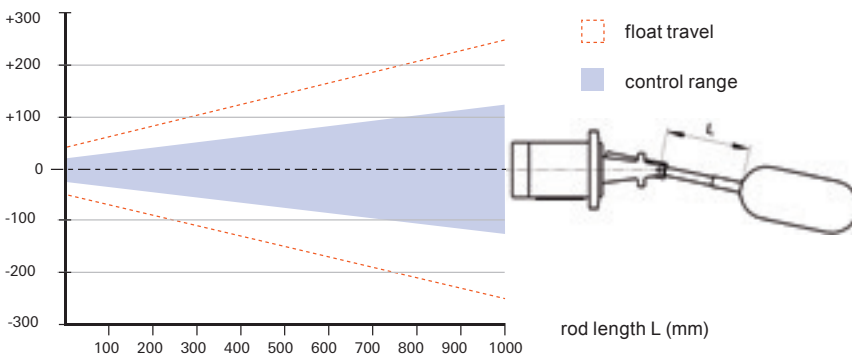

**Control range**

The normal control range is 30 mm, i.e. +15 mm/-15 mm from the centre line, measured in water at 20°C. With the float in the central position, the output is 0.6 bar. The control range can be increased by lengthening the float arm (see graph left).

**Type 5M 01 04 – For critical environments or high temperatures**

All parts stainless steel. As M 01 04, but housing also in stainless steel (CrNiMo) and therefore, highly corrosion resistant and suitable for operating temperatures up to 300°C. Weight approximately 2.2 kg.

**Type MV 01 04 – For moist control air**

As M 01 04, but with drain valve for condensate removal.

**Type FM 01 04 – For hazardous applications**

As M 01 04, but functionally tested. With declaration of conformity for use in explosion proof areas.

**Type FMV 01 04 – For moist control air in hazardous applications**

As FM 01 04, but with drain valve for condensate removal. With declaration of conformity for use in explosion proof areas.

**Control function**

The standard air connection configuration is shown here (fig. A). When filling, the output signal is decreasing proportionally to the rising level. The reverse function is obtained by turning the switch housing 180°C (see fig. B). This can be accomplished without interrupting the process.

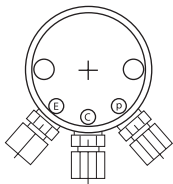

figure A

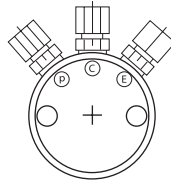
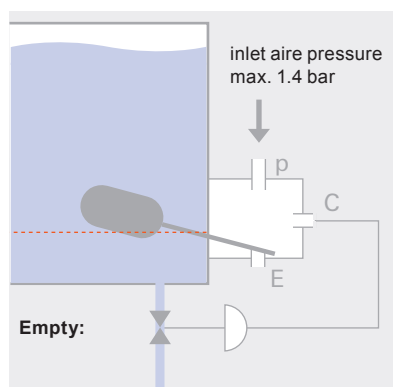
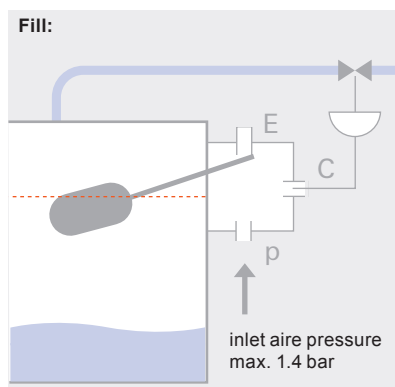

figure B





## The Industrial Range offers numerous flange combinations

The main feature of the Industrial Range is the wide choice of flange modules, manufactured according to international standards such as EN/DIN, ANSI or JIS. Available in various steel qualities, nominal sizes and pressure ratings (e.g. up to PN 250 acc. to EN/DIN or cl. 1500 acc. to ANSI). Shown here are only a few typical combinations, many more possibilities can be found in the module descriptions. All types in the Standard Range shown on the previous pages can of course also be combined with industrial flanges.

### Type A 22C 04 – For general purpose

Nominal pressure	PN 40
Operating temperature	0 to 330°C
Ambient temperature	0 to 70°C
Density of liquid	min. 0.7 kg/dm <sup>3</sup>
Operating differential	fixed 12 mm
Rod extensions	see page 34
Wetside material	Stainless steel (CrNiMo)
Flange material	Seal part: Stainless steel (CrNiMo) Slip-on Flange: Carbon steel P265GH, zinc galvanised and passivated
Housing material	Sea water resistant die cast aluminium
Flange	DN 65, PN 40 acc. to EN 1092-1
Flange facing	Raised face type B1
Switch element	Microswitch SPDT with silver contacts
Switch rating	250 VAC, 5 A 30 VDC, 5 A
Enclosure	IP65
Weight	approx. 5.4 kg
Safety Integrity Level (SIL)	SIL 1 (Type AA 22C 04: SIL 2)

Frequently used on off-shore rigs, in steam boilers and plants, power stations, chemical and petrochemical engineering, heating and refrigeration, i.e. airconditioning technology.

**SIL**  
IEC 61508/1511 SIL 3 Capable

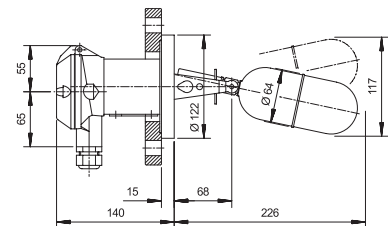

### Type B 132R 07 – For low voltage circuits and low density liquids

For use in low-voltage controls or logic circuits. Especially when long downtimes or sulfur-containing environments are to be expected. For hazardous area see also Ex-level switches page 40.

Nominal pressure	ANSI cl. 300
Operating temperature	0 to 330°C
Ambient temperature	0 to 70°C
Density of liquid	min. 0.5 kg/dm <sup>3</sup>
Operating differential	fixed 12 mm
Wetside material	Stainless steel (CrNiMo)
Flange material	Seal part: Stainless steel (CrNiMo) Slip-on Flange: Carbon steel P265GH, zinc galvanised and passivated
Housing material	Sea water resistant die cast aluminium
Flange	DN 3", PN cl. 300 ANSI B16.5
Flange facing	Raised face
Switch element	Microswitch SPDT with gold plated
Enclosure	IP65
Weight	approx. 8.6 kg
Safety Integrity Level (SIL)	SIL 1 (Type BB 132R 07: SIL 2)

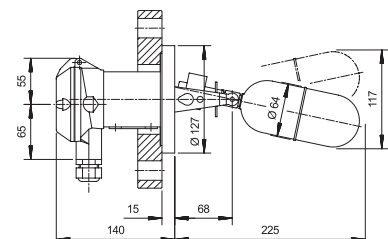
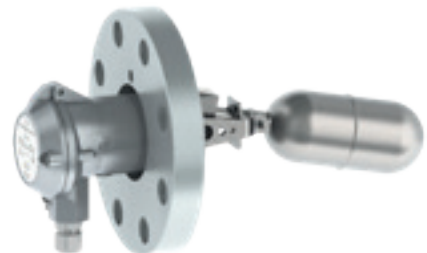

**Type HA 24E 02 – For high temperature**

Nominal pressure	PN 100
Operating temperature	0 to 400°C
Ambient temperature	0 to 135°C
Density of liquid	min. 0.7 kg/dm <sup>3</sup>
Operating differential	fixed 12 mm
Rod extensions	see page 34
Wetside material	Stainless steel (CrNiMo)
Flange material	Seal part: Stainless steel (CrNiMo) Slip-on Flange: Carbon steel P265GH, zinc galvanised and passivated
Housing material	seawater resistant, die cast aluminium
Flange	DN 65, PN 100 acc. to EN 1092-1
Flange facing	Raised face type B2
Switch element	Microswitch SPDT with silver contacts
Switch rating	250 VAC, 5 A 30 VDC, 5 A
Enclosure	IP65
Weight	approx. 9.6 kg
Safety Integrity Level (SIL)	SIL 1 (Type HAA 24E 02: SIL 2)

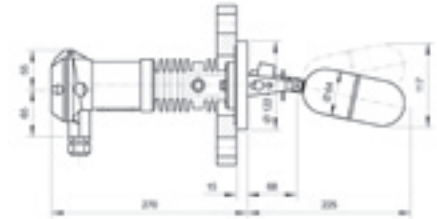
**Type 5TDI 22CF 041 – For low temperature and severe environmental conditions**

Completely in stainless steel with fixed flange.  
For hazardous area see also Ex-level switches page 40.

Nominal pressure	PN 40
Operating temperature	-196°C to 270°C
Ambient temperature	-10°C to 80°C
Density of liquid	min. 0.7 kg/dm <sup>3</sup>
Operating differential	fixed 12 mm
Wetside material	Stainless steel (CrNiMo)
Flange material	Stainless steel (CrNiMo)
Housing material	Stainless steel (CrNiMo)
Flange	DN 65, PN 40 acc. to EN 1092-1
Flange facing	Raised face type B1
Switch element	Inductive proximity switch acc. to NAMUR/EN 60947-5-6
Nominal voltage	8.2 VDC ±5%
Operating voltage	5 to 25 VDC
Current output	Proximity open: ≥2.2 mA float down Proximity closed: ≤1 mA float up
Function	as high alarm: at closed circuit as low alarm: at operating circuit
For inverse function	Type 5TDIN 22CF 041
Enclosure	IP66/IP67
Weight	approx. 7.7 kg
Safety Integrity Level (SIL)	SIL 1

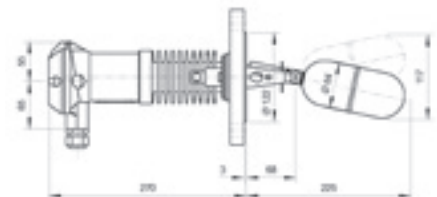

## The Plastic Range for corrosive or high purity media

The main feature of the Plastic Range is that all wetside materials are in corrosion resistant plastics such as PP or PTFE. Following are two typical examples, but these are by no means the limit of possible combinations which can be specified by reference to the module descriptions on pages 20 to 34.

### Type A 301 99 – For general use in PP

Nominal pressure	PN 10	max. 10 bar up to 25°C max. 5 bar at 45°C max. 2.5 bar at 60°C
Operating temperature	0 to 60°C	
Ambient temperature	0 to 60°C	
Density of liquid	min. 0.65 kg/dm <sup>3</sup>	
Operating differential	fixed 12 mm	
Rod extensions	see page 34	
Wetside material	PP	
Flange material	Seal part: PP Slip-on Flange: PVC	
Housing material	Sea water resistant die cast aluminium	
Flange	DN 80, PN 10 acc. to EN 1092-1	
Flange facing	Raised face type B1	
Switch element	Microswitch SPDT with silver contacts	
Switch rating	250 VAC, 5 A 30 VDC, 5 A	
Enclosure	IP65	
Weight	approx. 1.9 kg	

### Vacuum Applications:

For vacuum duty a modified sealing must be used, suffix to flange code is E20, e.g. A 301E20 99. This must be specified in the purchase order. The vacuum sealing unit is capable of operating to 0 bar absolute pressure.

**Proven application areas:** chemical and petrochemical engineering, pulp and paper, electroplating, food industry, etc.

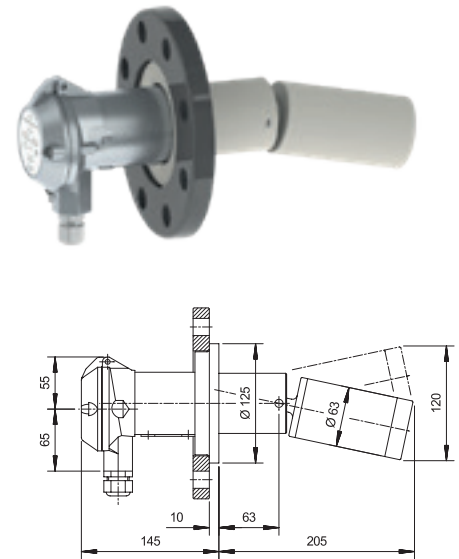

### Type A 304 98 – For high temperature and corrosive applications in PTFE

Nominal pressure	PN 6	max. 6 bar up to 65°C max. 4.5 bar at 100°C max. 3 bar at 200°C
Operating temperature	0 to 200°C	
Ambient temperature	0 to 70°C	
Density of liquid	min. 0.75 kg/dm <sup>3</sup>	
Operating differential	fixed 12 mm	
Rod extensions	see page 34	
Wetside material	PTFE	
Flange material	Seal part: PTFE 25% GRP Slip-on Flange: Carbon steel P265GH, zinc galvanised and passivated	
Housing material	Sea water resistant die cast aluminium	
Flange	DN 80, PN 10 acc. to EN 1092-1	
Flange facing	Raised face type B1	
Switch element	Microswitch SPDT with silver contacts	
Switch rating	250 VAC, 5 A 30 VDC, 5 A	
Enclosure	IP65	
Weight	approx. 5 kg	

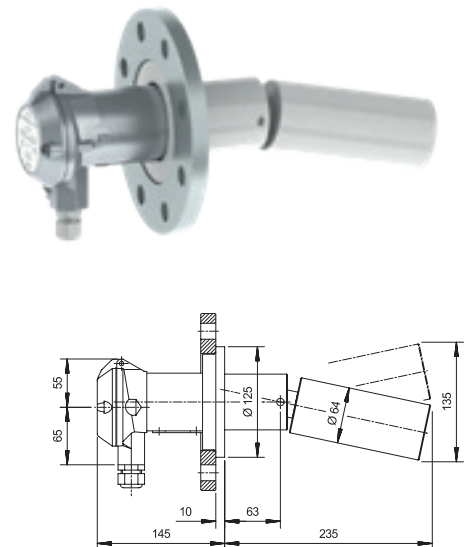

## Switch modules

The switch module is selected according to the type of control required, switching capability, environmental conditions and the working temperature in the vessel. The key on page 21 shows how the designation code is structured. The details of the switch modules are listed in the following tables 1 to 11. In accordance with the relevant EU-directives resp. UK Regulations and where applicable, Trimod Besta level switches are marked  $\text{CE}$  resp.  $\text{UKA}$ .

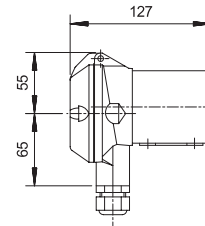

**Table 1**

### Electrical/Electronic Basic Modules, IP65

With 1 or 2 switches, galvanically isolated and with earthed encapsulation. Enclosure type IP65. Housing in sea water resistant die cast aluminium, with cable gland M20x1.5.

Type	Function	SIL	Rating	* Temperature in °C		Connection diagram
				Operating	Ambient	
A	SPDT Microswitch with silver contacts	SIL 1	250 VAC, 5 A 30 VDC, 5 A	0 to 330	0 to 70	
AA	Dual SPDT Microswitches with silver contacts, galvanically isolated	SIL 2	250 VAC, 5 A 30 VDC, 5 A	0 to 330	0 to 70	
B	SPDT Microswitch with gold plated contacts	SIL 1	0.3 A / 30 VDC	0 to 330	0 to 70	
BB	Dual SPDT Microswitches with gold plated contacts, galvanically isolated	SIL 2	0.3 A / 30 VDC	0 to 330	0 to 70	
I	Proximity switches acc. to NAMUR/EN 60947-5-6. As high alarm in the quiescent current mode or as a low alarm in the working current mode. Float up: Proximity switch damped: $I \leq 1$ mA Float down: Proximity switch undamped: $I \geq 2.2$ mA	SIL 1	$U_N 8.2$ VDC $\pm 5\%$ ( $U_B 5$ to 25 VDC)	0 to 150	0 to 70	
IN	Proximity switches acc. to NAMUR/EN 60947-5-6. As low alarm in the quiescent current mode or as a high alarm in the working current mode. Float up: Proximity switch undamped: $I \geq 2.2$ mA Float down: Proximity switch damped: $I \leq 1$ mA	SIL 1	$U_N 8.2$ VDC $\pm 5\%$ ( $U_B 5$ to 25 VDC)	0 to 150	0 to 70	
II	Dual proximity switches acc. to NAMUR/EN 60947-5-6. High/low level, galvanically isolated. Combination of I and IN.	SIL 1	$U_N 8.2$ VDC $\pm 5\%$ ( $U_B 5$ to 25 VDC)	0 to 150	0 to 70	
IE9	Self-checking proximity switch acc. to NAMUR/EN 60947-5-6, TÜV approved. As high alarm in the quiescent current mode. Float up: proximity switch damped: $I \leq 1$ mA For self-checking operate in quiescent current mode.	SIL 1	$U_N 8.2$ VDC $\pm 5\%$ ( $U_B 5$ to 25 VDC)	0 to 150	0 to 70	
INE9	Self-checking proximity switch acc. to NAMUR/EN 60947-5-6, TÜV approved. As low alarm in the quiescent current mode. Float down: proximity switch damped: $I \leq 1$ mA For self-checking operate in quiescent current mode	SIL 1	$U_N 8.2$ VDC $\pm 5\%$ ( $U_B 5$ to 25 VDC)	0 to 150	0 to 70	
IIE9	Dual self-checking proximity switches acc. to NAMUR/EN 60947-5-6, TÜV approved. High/low level, galvanically isolated. Combination of IE9 and INE9.	SIL 1	$U_N 8.2$ VDC $\pm 5\%$ ( $U_B 5$ to 25 VDC)	0 to 150	0 to 70	

\* The combinations of the temperature maximum values are to be avoided. Actual values must be requested from the manufacturer!

# Key to type numbers

## Switch module

Prefix

Basic module

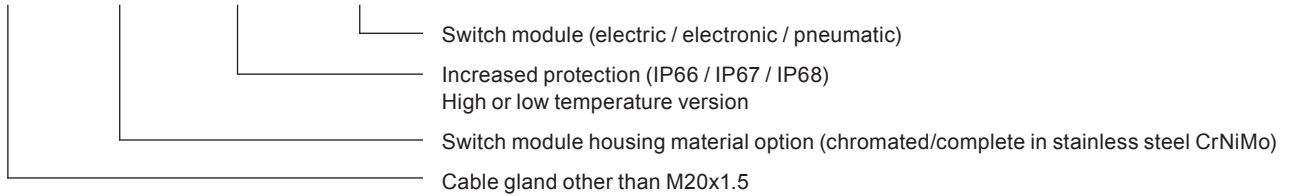
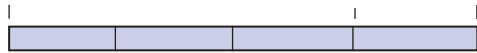

## Flange module

Page 25



## Float module

Page 30



## Thread for cable gland

The types in tables 1, 2, 4 and 5 are available on request with a cable gland thread other than M20x1.5.

Prefix	Cable gland
10	Marine execution (DIN 89280), Type W
30	Marine execution (DIN 89280), Type Z
40	Internal thread 3/4" NPT (without cable gland)

## Housing material coatings for enhanced requirements

### Chromated housing (ROHS conform)

The types in tables 1, 2 and 7 are also available with chromated housing. The designation prefix is 2. The types in tables 3, 4, 5, 8 and 9 are chromated as standard.

**Example: 2DA or Z2K8**

### Stainless steel housing (CrNiMo/316SS)

All switch modules in tables 1 to 9 are also available in stainless steel. The designation prefix is 5.

**Example: 5DA or Z5K8**

### Epoxy coated housing

Most switches are available with Epoxy coating.

Designation suffix: E46 Epoxy coating grey

**Example: DAE46**

Table 2

**Increased protection enclosure IP66/IP67**

All basic modules in table 1 are also available in IP66/IP67. The designation prefix is D. All data in table 1, except for the temperature rating remain unchanged. For high temperatures (operating -40°C to +200°C, ambient -40°C to +120°C), add E28, e.g. DAE28



Type	* Temperature in °C	
	Operating	Ambient
DA / DAA	-30 to 120	-30 to 120
DB / DBB	-30 to 120	-30 to 120
DI / DIN / DII	-30 to 120	-20 to 90
DIE9 / DINE9 / DIIIE9	-30 to 120	-30 to 90

Safety Integrity Level (SIL)  
Types DA / DB: SIL 1  
Types DAA / DBB: SIL 2  
Types DI / DIN / DII / DIE9 / DINE9 / DIIIE9: SIL 1

Table 3

**Submersible version IP68**

All basic modules in table 1 are also available for submerged applications (IP68) to 100 m depth with chromated housing. The designation prefix is U3, U5 or U11. The designation 3, 5 and 11 specifies standard lengths of encapsulated cable in meters (longer cables are available). All data in table 1, except for temperature rating, remain unchanged. Housing: chromated.



Type	* Temperature in °C	
	Operating	Ambient
U3A / U3AA	-30 to 80	-30 to 80
U3B / U3BB	-30 to 80	-30 to 80
U3I / U3IN / U3II	-25 to 80	-25 to 80
U3IE9 / U3INE9 / U3IIIE9	-30 to 80	-30 to 80

Safety Integrity Level (SIL)  
Types U3A / U3B: SIL 1  
Types U3AA / U3BB: SIL 2  
Types U3I / U3IN / U3II / U3IE9 / U3INE9 / U3IIIE9: SIL 1

Table 4

**High operating temperature**

All basic modules in table 1 are also available in a high temperature version with chromated housing IP65. The designation prefix is H. All data in table 1, except for temperature rating and connection diagram, remain unchanged.



Type	* Temperature in °C	
	Operating	Ambient
HA / HAA	0 to 400	0 to 135
HB / HBB	0 to 400	0 to 135
HI / HIN / HII	0 to 300	0 to 75
HIE9 / HINE9 / HIIIE9	0 to 300	0 to 75

Safety Integrity Level (SIL)  
Types HA / HB: SIL 1  
Types HAA / HBB: SIL 2  
Types HI / HIN / HII / HIE9 / HINE9 / HIIIE9: SIL 1

Table 5

**Low operating temperature**

All basic modules in table 1 are also available in a low temperature version with chromated housing IP66/IP67. The designation prefix is TD. All data in table 1, except for temperature rating and connection diagram, remain unchanged.



Type	* Temperature in °C	
	Operating	Ambient
TDA / TDAA	-196 to 270	-10 to 80
TDB / TDBB	-196 to 270	-10 to 80
TDI / TDIN / TDII	-196 to 270	-10 to 80
TDIE9 / TDINE9 / TDIIIE9	-196 to 270	-10 to 80

Safety Integrity Level (SIL)  
Types TDA / TDB: SIL 1  
Types TDAA / TDBB: SIL 2  
Types TDI / TDIN / TDII / TDIE9 / TDINE9 / TDIIIE9: SIL 1

\* The combinations of the temperature maximum values are to be avoided. Actual values must be requested from the manufacturer!

Table 6

**Ex-Switches for intrinsically safe circuits (Ex-i)**

The level switches with switch modules of types I, IE9 and B are designed also for use in hazardous areas, Zone 1 (EPL b), float: Zone 0 (EPL a) Technical details, see page 40.

**Example: IE98.**

Approved types	Designation	Type acc. to	Approval authority	Classification	Certificate
I... / IE9...	8	2014/34/EU	BV CPS	Ex ia IIC T6...T1 Ga/Gb	EPS 12 ATEX 1430 X
I... / IE9...	5	IECEX Scheme	BV CPS	Ex ia IIC T6...T1 Ga/Gb	IECEX EPS 15.0038 X
I... / IE9...	7	UK SI 2016 No. 1107	BV CPS	Ex ia IIC T6...T1 Ga/Gb	EPS 22 UKEX 1261 X
B...	8	2014/34/EU	BV CPS	Ex ia IIC T6 Ga/Gb	EPS 12 ATEX 1430 X
B...	5	IECEX Scheme	BV CPS	Ex ia IIC T6 Ga/Gb	IECEX EPS 15.0038 X
B...	7	UK SI 2016 No. 1107	BV CPS	Ex ia IIC T6 Ga/Gb	EPS 22 UKEX 1261 X

**Table 7**

**Hermetically sealed Ex-Switches for use in Zone 1 (EPL b), float: Zone 0 (EPL a)**

The type «eb» (increased safety) housing is equipped with 1 or 2 «db» (flameproof) microswitches, galvanically isolated with earthed encapsulation. Enclosure type: IP66/IP67



Housing in sea water resistant die cast aluminium or optional stainless steel; prefix «5».

Cable gland thread: M20x1.5 (without cable gland)

Type	Function	SIL	* Temperature in °C		Connection diagram
			Operating	Ambient	
ZK.	SPDT Microswitch with silver contacts	SIL 1	-30 to 200	-45 to 80	
ZKK.	Dual SPDT Microswitches, galvanically isolated, with silver contacts	SIL 2	-30 to 200	-45 to 80	

**Switching rating:** 250 VAC, 5A    30 VDC , 5 A  
 50 VDC , 3 A  
 75 VDC , 1 A  
 125 VDC , 0.5 A  
 250 VDC , 0.25 A

**Table 8**

**Submersible version IP68**

All modules in table 7 are also available for submerged applications (IP68) to 100 m depth. The designation prefix is U3, U5, U11 etc. The designation 3, 5, 11 etc. specifies standard lengths of encapsulated cable in meters (other cable lengths are available). All data in table 7, except for temperature rating, remain unchanged. Housing: chromated. Only permitted for certification designation 5, 7 and 8!



Type	* Temperature in °C	
	Operating	Ambient
ZU..K., ZU..KK.	-30 to 80	-30 to 80

Safety Integrity Level (SIL)  
 Type ZU..K.: SIL 1  
 Type ZU..KK.: SIL 2

**Table 9**

**High and low operating temperature**

All basic modules in table 7 are also available in a high/low temperature version with chromated housing to IP66/IP67.

The designation prefix is ZHT or optional stainless steel; prefix is Z5HT.

Connection diagram see table 7.



Type	* Temperature in °C	
	Operating	Ambient
ZHTK. / ZHTKK.	-196 to 380	-45 to 80

Safety Integrity Level (SIL)  
 Type ZHTK: SIL 1  
 Type ZHTKK: SIL 2

\* The combinations of the temperature maximum values are to be avoided. Actual values must be requested from the manufacturer!

**Table 10**

**Designation code and approval for hermetically sealed Ex-Switches, Type Z**

The designation number refers to the Certificate of Conformity and follows the module type. Example: ZK8

Designation	Type acc. to	Approval authority	Classification	Certificate
8	2014/34/EU	BV CPS	Ex eb db IIC T6...T5 Ga/Gb	EPS 12 ATEX 1430 X
5	IECEx Scheme	BV CPS	Ex eb db IIC T6...T5 Ga/Gb	IECEx EPS 15.0038 X
7	UK SI 2016 No. 1107	BV CPS	Ex eb db IIC T6...T5 Ga/Gb	EPS 22 UKEX 1261 X

Table 11

**Pneumatic modules**

The pneumatic modules are described in detail on pages 14 to 16.  
The housings are in sea water resistant aluminium. Pressure connections: G 1/8" (BSPP) inside thread.



Type	Function	Connection diagram	* Temperature in °C Operating	Ambient
<b>P</b>	Pneumatic switch with ON/OFF 3/2 way valve. Input air pressure 0 to 10 bar		1 to 250	1 to 80
<b>PV</b>	Pneumatic switch with ON/OFF 3/2 way valve and drain valve for condensate removal. Input air pressure 0 to 10 bar		1 to 250	1 to 80
<b>FP</b>	Pneumatic switch with ON/OFF 3/2 way valve, 0 to 10 bar function checked, may be used in hazardous areas.		1 to 250	1 to 80
<b>FPV</b>	Pneumatic switch with ON/OFF 3/2 way valve, 0 to 10 bar function checked, may be used in hazardous areas with drain valve for condensate removal.		1 to 250	1 to 80
<b>M</b>	Pneumatic proportional control valve, input air pressure 1.4 bar (max. 10 bar). Output signal 0.2 to 1 bar (3-15 psi).		1 to 250	1 to 80
<b>MV</b>	Pneumatic proportional control valve and drain valve for condensate removal. Input air pressure 1.4 bar (max. 10 bar). Output signal 0.2 to 1 bar (3-15 psi).		1 to 250	1 to 80
<b>FM</b>	Pneumatic proportional control valve, input air pressure 1.4 bar (max. 10 bar). Output signal 0.2 to 1 bar (3-15 psi) function checked may be used in hazardous areas.		1 to 250	1 to 80
<b>FMV</b>	Pneumatic proportional control valve and drain valve for condensate removal. Input air pressure 1.4 bar (max.10 bar). Output signal 0.2 to 1 bar (3-15 psi) function checked, may be used in hazardous areas.		1 to 250	1 to 80

\* The combinations of the temperature maximum values are to be avoided.  
Actual values must be requested from the manufacturer!

**Chromated housing**

The types in table 11 are also available with chromated housing. Designation prefix is 2.  
**Example: 2P or F2M**

**Stainless steel housing**

All switch modules in table 11 are also available in stainless steel.  
The operating temperature range is increased to 400°C.  
Designation prefix is 5.  
**Example: 5MV or F5MV**



# Flange modules

The flange module is selected according to the required flange standard, nominal pressure rating (PN), nominal size (DN), type of gasket, properties of the medium and flange material. A basic distinction is made between flange modules for the Standard Range, the Industrial Range and the Plastic Range. The flange modules may be installed either horizontally or vertically.

**Pressure equipment directive (PED):**  
For switches according to directive 2014/68/EU add the letter «P» after flange name. e.g. A 01P 041

**Table 12**  
**Flange modules for the Standard Range**

**Type Standard flanges**

<b>01</b>	<b>Square flange incl. gasket</b>
Material	1.4408
Nominal pressure	PN 25, max. 25 bar up to 300°C
Flange facing	Raised face
Temperature range	-196 to 300°C
Counterflange	see page 36

<b>011</b>	<b>Round flange incl. gasket</b>
Material	1.4571
Nominal pressure	PN 25, max. 25 bar up to 300°C max. 23 bar at 400°C
Flange facing	Raised face
Temperature range	-196 to 400°C
Counterflange	see page 36

**Type Special flanges**

<b>03</b>	<b>Round flange incl. gasket</b>
Material	1.4571
Nominal pressure	PN 25, max. 25 bar up to 300°C max. 23 bar at 400°C
Flange facing	Raised face
Temperature range	-196 to 400°C

<b>04</b>	<b>Round flange incl. gasket</b>
Material	1.4571
Nominal pressure	PN 25, max. 25 bar up to 300°C max. 23 bar at 400°C
Flange facing	Raised face
Temperature range	-196 to 400°C

<b>06</b>	<b>Round flange incl. gasket</b>
Material	1.4571
Nominal pressure	PN 25, max. 25 bar up to 300°C max. 23 bar at 400°C
Flange facing	Raised face
Temperature range	-196 to 400°C

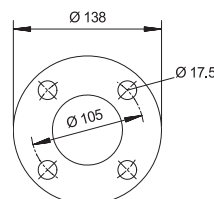
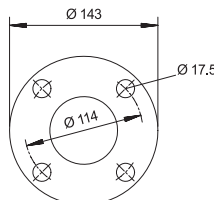
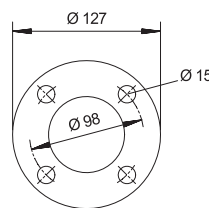
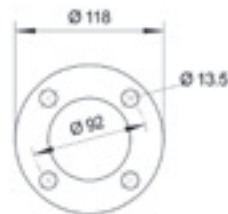
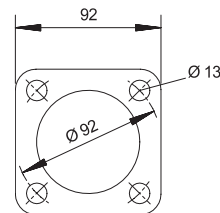

## Key to type numbers

### Switch module

Page 20



### Flange module

Table 12 to 14



### Float module

Page 30



(Table 13)

Other bracket length than 68 mm, and/or fixed flange execution and/or other materials, and/or PED conformity

Flange facing

Nominal pressure (PN)

Nominal bore (DN)

Standard (for EN/DIN without code)

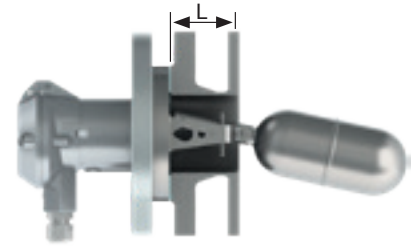

#### Important note:

Ensure that nozzle length L and diameter provide sufficient clearance for float movement. See table 23, page 33.

### Flange modules for the Industrial Range acc. to EN/DIN, ANSI, JIS

For economic reasons, the flange modules of the Industrial Range are manufactured in two different executions. The fixed flange for the most demanding requirements in respect of temperature range and corrosion resistance and the composite flange for best economy.

#### Fixed flange

Temperature range	-196 to 400°C
Material	1.4571
Options	1.4435 (316L), Hastelloy C
	If a fixed flange is required please consult us to select the correct type number.
	Type designation see table 13.

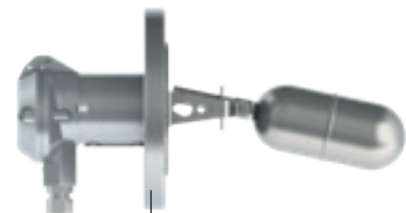

Fixed flange: 1.4571

#### Composite flange

Temperature range	-10 to 400°C (EN/DIN)
	-29 to 400°C (ANSI)
Materials	Sealing unit 1.4571 (316Ti)
	Slip-on Flange Carbon steel P265GH zinc galvanized and passivated
Options	Sealing unit 1.4435 (316L), Hastelloy C
	Type designation see table 13.
	Slip-on Flange 13 CrMo 4-5 (high temp. steel)
	A 350-LF2 (low temp. steel)

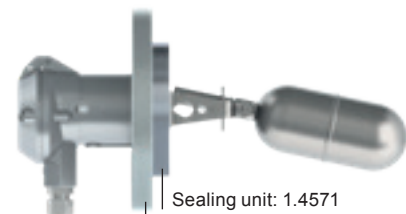

Sealing unit: 1.4571

Slip-on Flange: Carbon steel P265GH zinc galvanized and passivated

Table 13

## Type of flange module according to EN 1092-1

	PN 16	PN 40	PN 63	PN 100	PN 160	PN 250
<b>DN 65</b>	21.	22.	23.	24.	25.	-
<b>DN 80</b>	31.	32.	33.	34.	35.	36.
<b>DN 100</b>	41.	42.	43.	44.	45.	46.
<b>DN 125</b>	51.	52.	53.	54.	-	-
<b>DN 150</b>	61.	62.	63.	64.	-	-

## Suffix for flange facings:

Raised face	type B1	C
Raised face	type B2	E
Male	type E	V
Groove	type D	N
Tongue face	type C	F
Groove for metal joint	DIN 2696	L

## Example:

EN/DIN Flange module, DN 65, PN 40, type E (male): **22V**

## Type of flange module according to ANSI B16.5

	cl. 150	cl. 300	cl. 400	cl. 600	cl. 900	cl. 1500
<b>DN 3"</b>	131.	132.	-	134.	135.	136.
<b>DN 4"</b>	141.	142.	143.	144.	145.	146.
<b>DN 5"</b>	151.	152.	153.	154.	-	-
<b>DN 6"</b>	161.	162.	163.	164.	-	-

## Suffix for flange facings:

Raised face	RF	R
Small male	SMF	M
Small tongue	STF	T
Small groove	SGF	G
Ring joint	RTJ	J

## Example:

ANSI-Flange module DN 4", PN cl. 900, small groove: **145G**

## Type of flange module according to JIS B 2220

	5K	10K	16K	20K	30K	40K	63K
<b>DN 65</b>	329.	320.	328.	321.	322.	323.	324.
<b>DN 80</b>	339.	330.	338.	331.	332.	333.	334.
<b>DN 100</b>	349.	340.	348.	341.	352.	343.	344.
<b>DN 125</b>	-	350.	-	351.	352.	353.	354.

## Suffix for flange facings:

Large raised face:	R
Male:	M
Tongue:	T
Groove:	G

## Example:

JIS-Flange module DN 80A, PN 30K, groove: **332G**

Types 5K: only fixed flange

Types 40K and 63K: only composite flange

Pressure/Temperature Diagram acc. to EN 1092-1 and ANSI B16.5

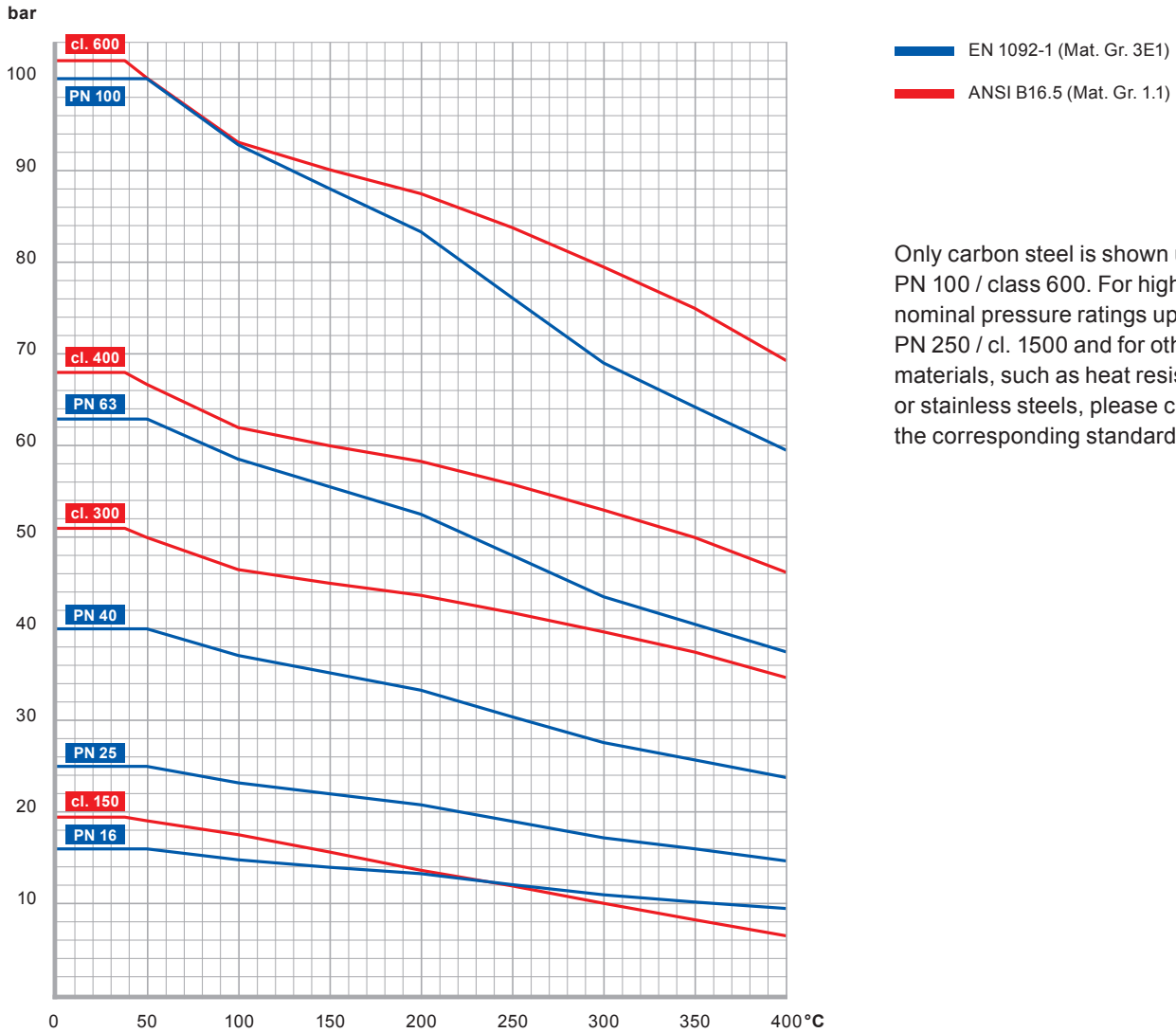

Only carbon steel is shown up to PN 100 / class 600. For higher nominal pressure ratings up to PN 250 / cl. 1500 and for other materials, such as heat resistant or stainless steels, please consult the corresponding standards.

Pressure/Temperature Diagram Plastics

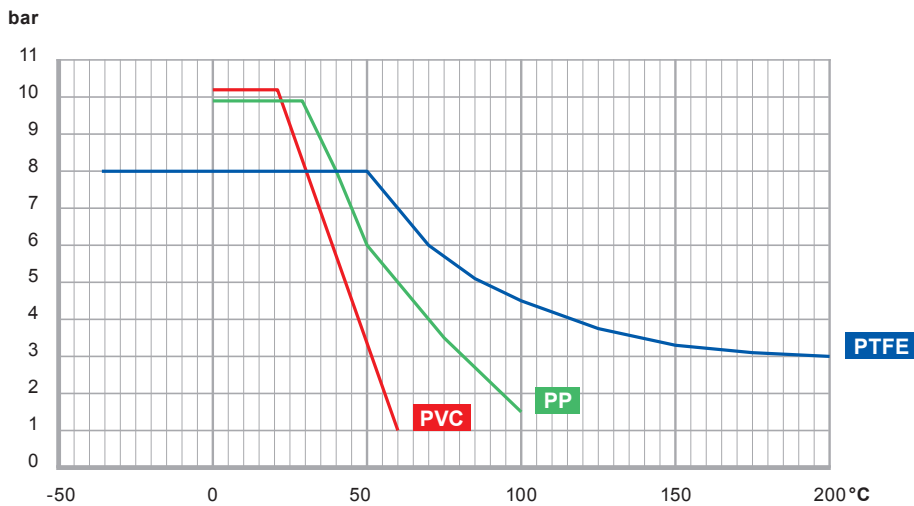

### Flange modules for the Plastic Range acc. to EN/DIN, ANSI, JIS

Wetted parts	PP (Polypropylene) or PTFE	
	Sealing unit in PTFE with 25% GRP	
	Option: sealing unit and pivot pin in Virgin-PTFE	
	Suffix: E104	
Slip-on Flange	PVC (for EN/DIN only) or P265GH (carbon steel), zinc galvanised and passivated	
	Option: stainless steel for low temp. application	
Flange facing	Raised face	
Temperature range	PP version with:	
	PVC-Slip-on Flange	0 to 60°C
	P265GH-Slip-on Flange	0 to 100°C
	PTFE version with:	
	PVC-Slip-on Flange	0 to 60°C
	P265GH-Slip-on Flange	-10 to 200°C (EN/DIN)
	P265GH-Slip-on Flange	-29 to 200°C (ANSI)
	Stainless steel slip-on Flange	-196 to 200°C
Pressure range	max. 10 bar	
Vacuum duty	The vacuum sealing unit is capable of operating to 0 bar absolute pressure, but this requirement must be specified in the purchase order.	
	Suffix PTFE version:	E19 (e.g. 302E19)
	Suffix PP version:	E20 (e.g. 301E20)

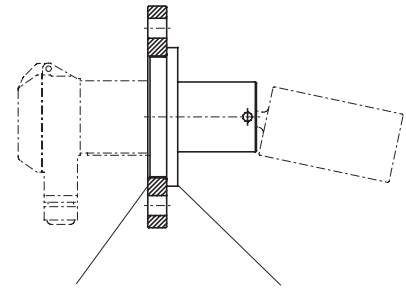

Slip-on flange PVC  
or P265GH  
Option:  
stainless steel 1.4571

Sealing unit  
PP or PTFE  
Option: pure PTFE

Table 14

#### Type of flange module according to EN 1092-1 PN 10

Material	DN 65	DN 80	DN 100	DN 125	DN 150
PVC / PP	-	301	401	501	601
PVC / PTFE	202	302	402	502	602
P265GH / PP	-	303	403	503	603
P265GH / PTFE	-	304	404	504	604
1.4571 / PP	-	307	-	-	-
1.4571 / PTFE	-	308	-	-	-

#### Type of flange module acc. to ANSI B16.5 PN cl. 150 reduced

Material	DN 3"	DN 4"	DN 5"	DN 6"
P265GH / PP	1313	1413	1513	1613
P265GH / PTFE	1314	1414	1514	1614
1.4571 / PP	1137	-	-	-
1.4571 / PTFE	1138	-	-	-

#### Type of flange module according to JIS B 2220 PN 10K

Material	DN 80	DN 100	DN 125	DN 150
P265GH / PP	3303	3403	3503	3603
P265GH / PTFE	3304	3404	3504	3604

## Float modules

The float module should be selected acc. to the following parameters:

1. Function (alarm or control)
2. Minimum liquid density
3. Operating pressure
4. Operating temperature
5. Wetted material
6. Solids content
7. Mounting horizontally, vertically or in chamber
8. For explosion-proof or non explosion-proof applications
9. Liquids

### Key to type numbers

#### Switch module

Page 20

#### Flange module

Page 25

#### Float module

Tables 15 to 27

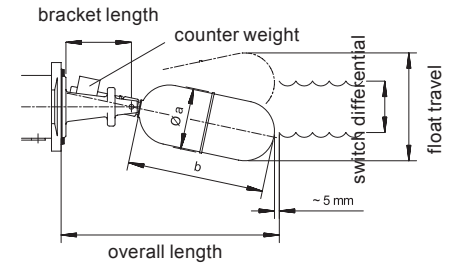
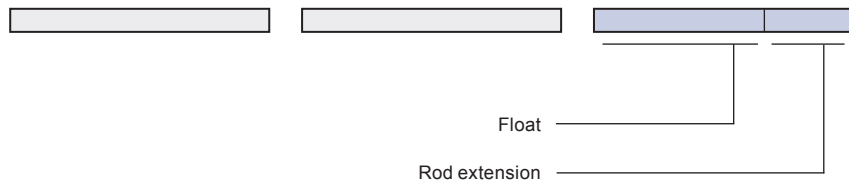

Rod extension see page 34

The most commonly used float modules are listed in tables 15 to 21. The choice of modules is, however, much greater. If you do not find the float you require, please ask us. Most float modules are also available in Hastelloy C. The type number changes e.g. from 04 to 404 etc. For exact type specification please ask.

NACE: stainless steel- and Hastelloy-floats are also available acc. to NACE Standard.

**Table 15**

#### Float modules with a 12 mm fixed differential

Float material: 1.4571 (SS316Ti equiv.)



Type	Float dimensions (mm) ø a x b	Bracket length (mm)	Overall length (mm)	Float travel (mm)	counter weight	Up to nominal pressure PN			Min. density (kg/dm <sup>3</sup> )	Approved for hazardous areas	Rod extensions (page 34)
						DIN bar	ANSI cl.	JIS bar			
01	64 x 110	68	194	104	-	40	300	30	0.8	x	G1, G2, G3
04	64 x 142	68	226	117	-	40	300	30	0.7	x	G1, G2, G3
041	64 x 142	68	226	117	-	40	300	30	0.7	x	-
07	64 x 142	68	226	117	x	40	300	30	0.5	x	G1, G2
76	64 x 200	102	316	114	x	63	400	40	0.4	x	G1, G2
02	64 x 142	68	224	117	x	100	600	63	0.7	x	G1, G2
26	64 x 200	102	316	114	x	100	600	63	0.35	x	G1, G2
27	64 x 142	102	321	115	x	100	600	63	0.5	x	G1, G2
03	64 x 142	102	258	98	x	250	1500	63	0.75	x	G1, G2
031	64 x 142	142	431	115	x	250	1500	63	0.7	x	G1, G2
032	64 x 142	142	421	112	x	250	1500	63	0.5	x	G1, G2

Table 16

Float modules with protective bellows and fixed operating differential 12 mm, float material: 1.4571 (SS316Ti equiv.)



Type	Float dimensions (mm) ø a x b	Bracket length (mm)	Overall length (mm)	Float travel (mm)	Counter-weight	Up to nominal pressure PN			Min. density (kg/dm <sup>3</sup> )	Approved for hazardous areas	Rod extension (page 34)	Bellows material
						EN/DIN bar	ANSI cl.	JIS Rating				
011	64 x 110	68	221	115	-	40	300	30K	0.8	x	G1, G2, G3	Perbunan
012	64 x 110	68	221	115	-	40	300	30K	0.8	-	G1, G2, G3	Silicon
013	64 x 110	68	221	115	-	40	300	30K	0.8	-	G1, G2, G3	FPM
051	64 x 142	68	253	129	-	40	300	30K	0.75	x	G1, G2, G3	Perbunan
052	64 x 142	68	253	129	-	40	300	30K	0.75	-	G1, G2, G3	Silicon
053	64 x 142	68	253	129	-	40	300	30K	0.75	-	G1, G2, G3	FPM
054	64 x 142	68	253	129	-	40	300	30K	0.75	-	G1, G2	PTFE
071	64 x 142	68	253	129	x	40	300	30K	0.5	x	G1, G2	Perbunan
072	64 x 142	68	253	129	x	40	300	30K	0.5	-	G1, G2	Silicon
073	64 x 142	68	253	129	x	40	300	30K	0.5	-	G1, G2	FPM
074	64 x 142	68	253	129	x	40	300	30K	0.5	-	G1, G2	PTFE
761	64 x 200	102	345	121	x	63	400	40K	0.45	x	G1, G2	Perbunan
762	64 x 200	102	345	121	x	63	400	40K	0.45	-	G1, G2	Silicon
763	64 x 200	102	345	121	x	63	400	40K	0.45	-	G1, G2	FPM
764	64 x 200	102	345	121	x	63	400	40K	0.45	-	G1, G2	PTFE

Perbunan = Buna (NBR)

Table 17

Float modules with adjustable differential for dual point control, float material: 1.4571 (SS316Ti equiv.)



Type	Float dimensions (mm) ø a x b	Bracket length (mm)	Overall length (mm)	Float travel (mm)	Operating differential (mm)	Counter-weight	Up to nominal pressure PN			Min. density (kg/dm <sup>3</sup> )	Approved for hazardous areas	Remarks
							EN/DIN bar	ANSI cl.	JIS Rating			
090	64 x 142	68	278	160 to 350	37 to 218	-	40	300	30K	0.8	x	switching differential see page 12
091	64 x 142	68	361	202 to 476	56 to 317	-	40	300	30K	0.75	x	
092	64 x 142	68	461	254 to 630	83 to 442	-	40	300	30K	0.75	x	
093	64 x 142	68	561	307 to 790	97 to 557	-	40	300	30K	0.75	x	
095	64 x 110	68	246	148 to 294	34 to 190	-	40	400	40K	0.9	x	

Table 18

Float modules for interface applications, horizontal mounting, float material: 1.4571 (SS316Ti equiv.)



Type	Float dimensions (mm) ø a x b	Bracket length (mm)	Overall length (mm)	Float travel (mm)	Counter-weight	Up to nominal pressure PN			Min. density (kg/dm <sup>3</sup> )	Approved for hazardous areas	Min. density difference	Rod extension (mm)
						EN/DIN bar	ANSI cl.	JIS Rating				
08T1	64 x 142	68	509	236	-	40	300	30K	0.75	x	0.1	300
			409	194	-	40	300	30K	0.75	x	0.14	200
			309	152	-	40	300	30K	0.8	x	0.22	100
28T1	64 x 142	102	541	174	x	100	600	63K	0.8	x	0.16	300
			441	147	x	100	600	63K	0.72	x	0.22	200
			341	120	x	100	600	63K	0.6	x	0.37	100

Table 19

Float modules with bellows for interface application,  
horizontal mounting, float material: 1.4571 (SS316Ti equiv.)



Type	Float dimensions (mm) ø a x b	Bracket length (mm)	Overall length (mm)	Float travel (mm)	Counter-weight	Up to nominal pressure PN			Min. density (kg/dm <sup>3</sup> )	Approved for hazardous areas	Min. density difference	Rod length (mm)	Bellows material
						EN/DIN bar	ANSI cl.	JIS Rating					
081T1	64 x 142	68	536	248	-	40	300	30K	0.8	x	0.1	300	Perbunan
			436	206	-	40	300	30K	0.8	x	0.13	200	Perbunan
			336	163	-	40	300	30K	0.9	x	0.19	100	Perbunan
082T1	64 x 142	68	536	248	-	40	300	30K	0.8	-	0.1	300	Silicon
			436	206	-	40	300	30K	0.8	-	0.13	200	Silicon
			336	163	-	40	300	30K	0.9	-	0.19	100	Silicon
083T1	64 x 142	68	536	248	-	40	300	30K	0.8	-	0.1	300	FPM
			436	206	-	40	300	30K	0.8	-	0.13	200	FPM
			336	163	-	40	300	30K	0.9	-	0.19	100	FPM
084T1	64 x 142	68	536	248	-	40	300	30K	0.8	-	0.1	300	PTFE
			436	206	-	40	300	30K	0.8	-	0.13	200	PTFE
			336	163	-	40	300	30K	0.9	-	0.19	100	PTFE

Perbunan = Buna (NBR)

Table 20

Plastic float modules with fixed operating differential 12 mm



Type	Float dimensions (mm) ø a x b	Bracket length (mm)	Overall length (mm)	Float travel (mm)	Counter-weight	Up to nominal pressure PN			Min. density (kg/dm <sup>3</sup> )	Material	Rod extension see page 34
						EN/DIN bar	ANSI cl.	JIS Rating			
98	64 x 150	68	240	132	-	8	150 <sup>a)</sup>	10K <sup>a)</sup>	0.75	PTFE	P1, V1, V2, V3
99	63 x 120	68	205	118	-	10	150 <sup>b)</sup>	10K <sup>b)</sup>	0.65	PP	K1, K2, K3

<sup>a)</sup> Max. operating pressure 8 bar (test pressure 13 bar)

<sup>b)</sup> Max. operating pressure 10 bar (test pressure 15 bar)

Table 21

Float modules for vertical mounting  
Float material: 1.4571 (SS316Ti equiv.)

Can be used as an alarm or pump control, for setting the switching differential and installation, see page 13.



Type	Float dimensions (mm) ø a x b	Bracket length (mm)	Overall length (mm)	Float travel (mm)	Counter-weight	Up to nominal pressure PN			Min.f) density (kg/dm <sup>3</sup> )	Approved for hazardous areas
						EN/DIN bar	ANSI cl.	JIS Rating		
140	120	68	1582	12 to 1340	x	16	150 <sup>d)</sup>	10K <sup>d)</sup>	0.45	-
141	120	68	3082	12 to 2840	x	16	150 <sup>d)</sup>	10K <sup>d)</sup>	0.45	-
145	120 x 164	68	1582	12 to 1300	x	25	150 <sup>d)</sup>	10K <sup>e)</sup>	0.45	x
146	120 x 164	68	3082	12 to 2800	x	25	150 <sup>d)</sup>	10K <sup>e)</sup>	0.45	x

<sup>d)</sup> Max. operating pressure 16 bar (test pressure 24 bar)

<sup>e)</sup> Max. operating pressure 25 bar (test pressure 38 bar)

<sup>f)</sup> Minimum density for pump control 0.45 kg/dm<sup>3</sup>, for alarm 0.3 kg/dm<sup>3</sup>



**Table 22**  
**Maximum operating temperature for float modules**

Float material	Temperature range in °C
Stainless steel 1.4571	-196 to 400
Polypropylene PP	0 to 100
Polytetrafluorethylene PTFE	-200 to 200
Polyamid-coated CrNiMo floats	-50 to 80
Halar-coated CrNiMo floats	-60 to 150

Bellow material	Temperature range in °C
Perbunan / Buna (NBR)	0 to 120
Silicon	-40 to 200
FPM	10 to 200
Polytetrafluorethylene PTFE	-200 to 250

Note: When selecting a float module also consider the temperature rating of the switch- and flange module.

**Table 23**  
**Maximum length of connection flange, L**

To allow sufficient float clearance a maximum length «L» for the connection flange is shown in the following table according to the type of float module and the nominal flange size (dimensions in mm).

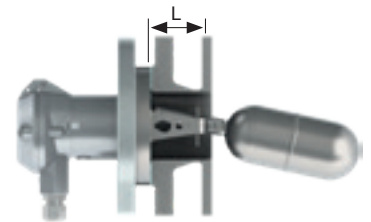

Nominal bore (flange)	Float module type												
	01	011 to 013	04 and 041	051 to 053	054	090	091	092	093	095	07	076	02
DN 65 acc. to EN 1092-1	80	105	80	105	70	70	70	70	70	70	80	110	80
DN 80 acc. to EN 1092-1	90	110	90	110	110	90	90	90	90	90	90	140	90
DN 100 acc. to EN 1092-1	∞	140	140	140	140	90	100	100	100	90	140	220	140
DN 125 acc. to EN 1092-1	∞	∞	∞	∞	∞	90	110	110	110	90	∞	∞	∞
DN 150 acc. to EN 1092-1	∞	∞	∞	∞	∞	90	120	120	120	90	∞	∞	∞
3" accord. to ANSI B16.5	90	110	90	110	110	90	90	90	90	90	90	140	90
4" accord. to ANSI B16.5	140	140	140	140	140	90	100	100	100	90	140	220	140
5" accord. to ANSI B16.5	∞	∞	∞	190	190	90	110	110	110	90	∞	∞	∞
6" accord. to ANSI B16.5	∞	∞	∞	∞	∞	90	120	120	120	90	∞	∞	∞



Minimum bore diameter for above listed float modules: ø 65 mm.

## Rod extensions

Where the float pivot needs to be protected from contaminated media or to provide an increased switching differential the float can be equipped with a rod extension.

**Table 24**

**Type of rod extensions (Dimensions in mm)**

Rod extension material	To match float modules			
Stainless steel (CrNiMo)	Stainless steel (CrNiMo)	Type: G1 A max: 1000 A min: 100	Type: G2 A+B max: 1000 A/B: ≤ 4 A min: 100 B min: 100	*Type: G3 A+B max: 1000 A/B: ≤ 4 A min: 50 B min: 60
PP	PP	Type: K1 A min: 100 A max: 1000	Type: K2 A+B max: 1000 A min: 100 B min: 200	Type: K3 A+B max: 1000 A/B: ≤ 3 A min: 100 B min: 100
PVDF	PTFE	Type: V1 A min: 100 A max: 1000	Type: V2 A+B max: 1000 A min: 100 B min: 200	Type: V3 A+B max: 1000 A/B: ≤ 4 A min: 100 B min: 100
PTFE	PTFE	Type: P1 A min: 100 A max: 300	-	-

\* Rod extension type G3 is available with 90° or 135° angle.

Since rod extensions add-on weight to the float, the minimum value for the density will change according to the following tables. Tables 25 to 27 list the minimum densities for float module 04 with extensions G1, G2 and G3 only. For other float modules and rod extensions with other dimensions or materials, please consult the factory.

**Table 25**

**Minimum density for float module 04G1**

Rod length A (mm)	100	200	300	400	500	600	700	800	900	1000
Min. density (kg/dm <sup>3</sup> )	0.66	0.66	0.67	0.69	0.71	0.74	0.76	0.79	0.81	0.84



**Table 26**

**Minimum density for float module 04G2 (kg/dm<sup>3</sup>)**

A (mm)	100	200	300	400	500	600	700	800
<b>B (mm)</b>								
<b>100</b>	0.69	0.68	0.70	0.71	0.72	0.74	0.75	-
<b>200</b>	0.67	0.67	0.68	0.69	0.70	0.71	0.72	0.73
<b>300</b>	0.68	0.69	0.69	0.70	0.71	0.71	0.72	
<b>400</b>	0.70	0.70	0.71	0.71	0.72	0.73		
<b>500</b>	0.72	0.73	0.73	0.73	0.74			
<b>600</b>	0.74	0.75	0.75	0.75				
<b>700</b>	0.77	0.77	0.77					
<b>800</b>	0.79	0.80						
<b>900</b>	0.82							



**Table 27**

**Minimum density for float module 04G3 (kg/dm<sup>3</sup>)**

A (mm)	50-500	600	700	800
<b>B (mm)</b>				
<b>50</b>	0.71	-	-	-
<b>100</b>	0.69	-	-	-
<b>200</b>	0.68	0.68	0.68	0.68
<b>300</b>	0.69	0.69	0.69	
<b>400</b>	0.71	0.71		
<b>500</b>	0.73			
<b>600</b>	0.75			
<b>700</b>	0.77			
<b>800</b>	0.80			
<b>900</b>	0.82			
<b>950</b>	0.83			



# Specification sheet

If you have a special requirement for a Trimod Besta level switch, please send us a completed copy of this specification sheet together with any relevant drawing etc. and we will respond with a quotation.

Liquid \_\_\_\_\_ Operating/ambient temperature \_\_\_\_\_ °C / \_\_\_\_\_ °C  
 Density \_\_\_\_\_ kg/dm<sup>3</sup> Tank material \_\_\_\_\_  
 Operating pressure \_\_\_\_\_ bar Tank measurement \_\_\_\_\_

**Application**

- High alarm
- Low alarm
- 2-point control
- Interface application
- Regulating (pneumatic)

**Type of mounting**

- Side mounted
- Top mounted
- In float chamber (by-pass)

**Switch module type**

Contact type	<b>Electric</b>		<b>Electronic</b>		<b>Pneumatic</b>
	<input type="checkbox"/> SPDT	<input type="checkbox"/> 2 x SPDT	<input type="checkbox"/> I	<input type="checkbox"/> IE9	<input type="checkbox"/> On/Off
	<input type="checkbox"/> Silver	<input type="checkbox"/> Gold plated	<input type="checkbox"/> IN	<input type="checkbox"/> INE9	<input type="checkbox"/> proportional
Safety Integrity Level (SIL)	<input type="checkbox"/> SIL 1	<input type="checkbox"/> SIL 2			
Approval classification	<input type="checkbox"/> Ex eb db IIC T6...T5 Ga/Gb (Microswitch Ex-db)		<input type="checkbox"/> Ex ia IIC T6 Ga/Gb (Microswitch gold contacts)		<input type="checkbox"/> Ex ia IIC T6...T1 Ga/Gb (Proximity switch)
Cable gland	<input type="checkbox"/> M20 x 1.5		<input type="checkbox"/> 3/4" NPT		
Enclosure material	<input type="checkbox"/> Die cast aluminium	<input type="checkbox"/> Die cast aluminium, chromated	<input type="checkbox"/> Stainless steel		
Enclosure rating	<input type="checkbox"/> IP65	<input type="checkbox"/> IP66/IP67	<input type="checkbox"/> IP68, cable length _____		
Remarks	_____				

**Flange module type**

Flange type	<input type="checkbox"/> Square flange 92 x 92	<input type="checkbox"/> Fixed Flange	<input type="checkbox"/> Slip-on Flange	
DN/PN	<input type="checkbox"/> ANSI	<input type="checkbox"/> EN/DIN	<input type="checkbox"/> DN _____	<input type="checkbox"/> PN _____ Seal type _____
Wetted parts material	<input type="checkbox"/> CrNiMo	<input type="checkbox"/> Hastelloy C	<input type="checkbox"/> PP	<input type="checkbox"/> PTFE Other _____
Slip-on Flange material	<input type="checkbox"/> Carbon steel P265GH zinc galvanized and passivated			Other _____
Remarks	_____			

**Float module type**

Float material	<input type="checkbox"/> CrNiMo	<input type="checkbox"/> Hastelloy C	<input type="checkbox"/> PP	<input type="checkbox"/> PTFE
Differential	<input type="checkbox"/> Fixed 12 mm	Variable between _____		
Bellows	<input type="checkbox"/> Perbunan (NBR)	<input type="checkbox"/> Silicon	<input type="checkbox"/> FPM	<input type="checkbox"/> PTFE
Remarks	_____			

**Options**

Float rod extension	<input type="checkbox"/> G1	<input type="checkbox"/> G2	<input type="checkbox"/> G3	Dim. A _____ mm Dim. B _____ mm
Counterflanges	<input type="checkbox"/> Carbon steel		<input type="checkbox"/> CrNiMo	
Test actuators	<input type="checkbox"/> CrNiMo / FPM		<input type="checkbox"/> CrNiMo / EPDM	
Test certificates (See page 6)	<input type="checkbox"/> EN 10204-2.1	<input type="checkbox"/> EN 10204-2.2	<input type="checkbox"/> EN 10204-3.1	<input type="checkbox"/> Test certificate - function test
Tag No.	_____			

## Accessories

### Counterflanges with and without test actuator

The simplest method of installing any Trimod Besta level switch of the Standard Range, is to use our standard weld-on counterflanges. There are carbon steel (GP240GH) and stainless steel (1.4408) versions in two different lengths available. The test actuator allows a periodic manual function check of the level switch in operating status. The function of the switching element (microswitch, proximity switch, pneumatic valve) and movement of the float can be tested.

### Counterflange not for use with the test actuator

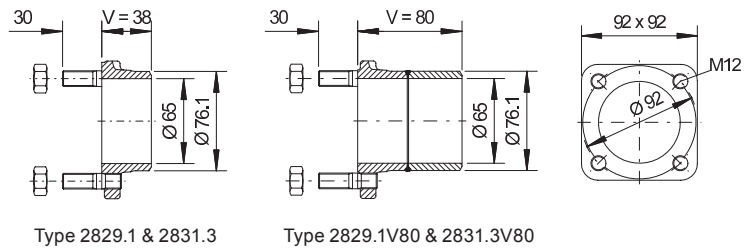
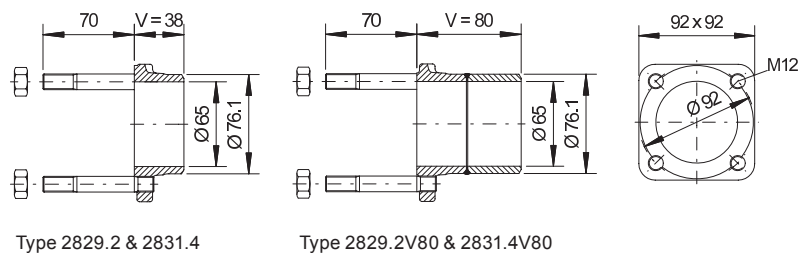

**Table 28**

Type	Flange length	Material Flange	Material Stud	Stud length	Temperature range in °C
2829.1	V = 38 mm	GP240GH	5.8	30 mm	-10 to 300
2831.3	V = 38 mm	1.4408	A2	30 mm	-196 to 400
2829.1V80*	V = 80 mm	GP240GH	5.8	30 mm	-10 to 300
2831.3V80*	V = 80 mm	1.4408	A2	30 mm	-196 to 400

Operating pressure: -1 to 25 bar

### Counterflange for use with the test actuator (Type 2382 & 2383)



**Table 29**

Type	Flange length	Material Flange	Material Stud	Stud length	Temperature range in °C
2829.2	V = 38 mm	GP240GH	5.8	70 mm	-10 to 300
2831.4	V = 38 mm	1.4408	A2	70 mm	-196 to 400
2829.2V80*	V = 80 mm	GP240GH	5.8	70 mm	-10 to 300
2831.4V80*	V = 80 mm	1.4408	A2	70 mm	-196 to 400

Operating pressure: -1 to 25 bar

**\*Important:**

Not for use in applications on top of the tank.

## Counterflange with test actuator

### Important:

Positioning of counterflanges with G 3/8" thread for test actuator. If the level switch is used for high alarm the thread has to look upwards. For a low level alarm, the thread has to look downwards.

Counterflange **V=50 mm** with test actuator

Table 30

Type	Material Flange	Material Stud	Material Test actuator	Material O-Ring	Temperature range in °C	Operating pressure in bar
2865	P250GH	5.8	1.4305/1.4404	FPM	0 to 150	-1 to 25
2866	P250GH	5.8	1.4305/1.4404	EPDM	-10 to 150	-1 to 25

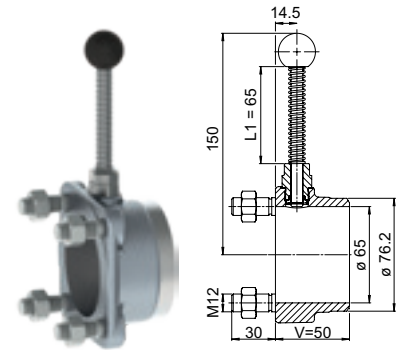

## Test actuator

The test actuators 2382 and 2383 can be used, if the tank is already equipped with a counterflange, type 2829.2, 2831.4, 2829.2V80 or 2831.4V80.

Table 31

Type	Material Test actuator	Material O-Ring	Temperature range in °C	Operating pressure in bar
2382	1.4305/1.4404	FPM	0 to 150	-1 to 25
2383	1.4305/1.4404	EPDM	-30 to 150	-1 to 25

Test actuators are supplied with flat gaskets.

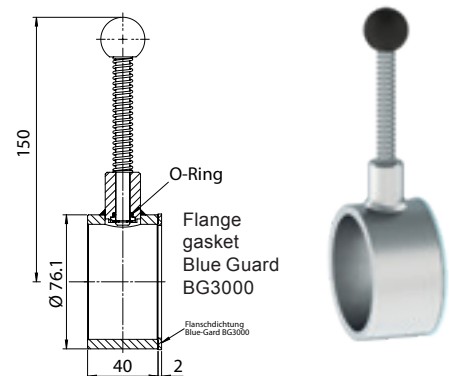

Table 32

Application	Use as high (HA) or low (LA) alarm	Mounting position
Checking switch function and float movement under operating conditions (PS = -1 to 25 bar)	HA	
	LA	

### Important:

For use of the counterflange on top of the tank (vertical switch) please contact us for correct application.



## Float chambers

Wherever it is not possible or desirable to install float switches directly onto a vessel, horizontal Trimod Besta level switches can be mounted externally in a float chamber. This type of installation allows functional checks and servicing to be carried out without interrupting operation, provided that isolation and drain valves are included in the process connections.

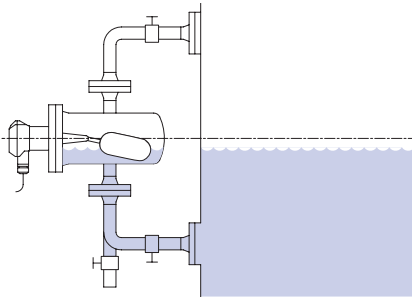

Float chambers may be divided into 2 groups.

### Standard chambers PN 25

In various steel qualities and configurations with process connection acc. to EN/DIN or ANSI.

For use with the Trimod Besta level switches from the standard range with:

Square flange type: 01 or  
Round flange type: 011

### Industrial chambers up to PN 250 acc. to EN/DIN or PN cl. 1500 acc. to ANSI

In various steel qualities and configurations with switch- and process connections acc. to EN/DIN or ANSI.

For use with the Trimod Besta level switches from the industrial range with EN/DIN-flanges DN 65 or ANSI-flanges DN 3".



Table 33

## Standard chambers PN 25

Types	According to figures A to H
Process connections	DN 25, 50 in accordance with EN/DIN DN 1", 2" in accordance with ANSI
Material	Carbon steel High temperature steel CrNi steel CrNiMo steel
Flange facing of process connections	in accordance with EN 1092-1 and ANSI B16.5
Options	<ul style="list-style-type: none"> <li>■ Special dimensions</li> <li>■ Vent and drain connection</li> <li>■ Long studs for mounting a test actuator</li> <li>■ Float chambers for low temperature applications</li> <li>■ Float chambers with max. hardness of HRC 22 in accordance with NACE</li> </ul>

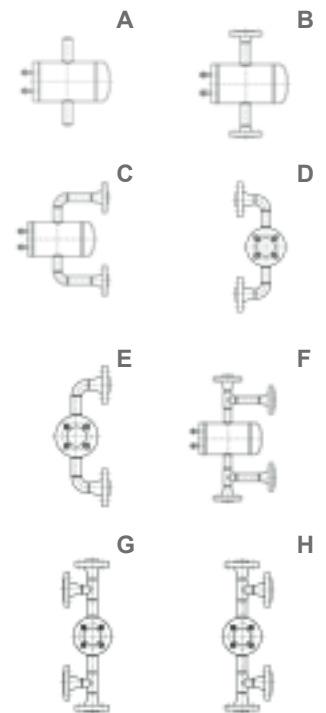
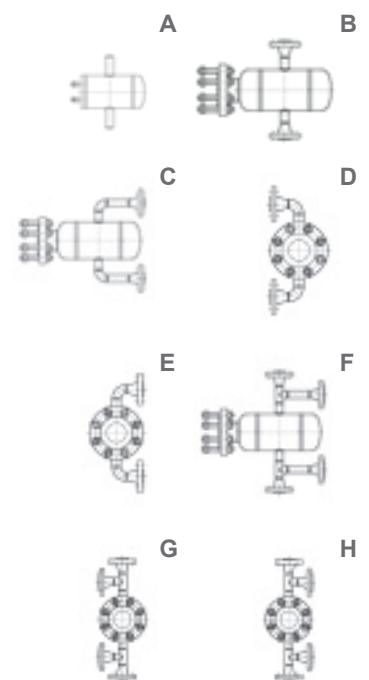

Table 34

## Industrial chambers PN 40 to PN 100 and ANSI PN cl. 150 to PN cl. 600

Types	According to figures A to H
Process connections	DN 25, 50 in accordance with EN/DIN DN 1", 2" in accordance with ANSI
Material	Carbon steel High temperature steel CrNi steel CrNiMo steel
Flange facing of process connections	in accordance with EN 1092-1 and ANSI B16.5
Options	<ul style="list-style-type: none"> <li>■ Special dimensions</li> <li>■ Vent and drain connection</li> <li>■ Chambers up to PN 250 in accordance with EN/DIN, PN cl. 1500 with ANSI</li> <li>■ Float chambers for low temperature applications</li> <li>■ Float chambers with max. hardness of HRC 22 in accordance with NACE</li> </ul>



For float chambers in tables 33 and 34, the following options, tests and documentation are available:

- incl. declaration of conformity according to 2014/68/EU
- incl. certificate of construction and pressure test
- incl. list of materials and material certificates 3.1
- Non-destructive material testing such as ultrasonic, X-ray or dye penetrant methods
- Priming and protective coatings

## Trimod Besta Level Switches in hazardous areas

For level monitoring in hazardous areas, the following Trimod Besta level switches are available:

### Hermetically sealed Trimod Besta Level Switches

These switches are available in three versions.

#### Protection classifications:

Ex eb db IIC T6...T5 Ga/Gb for switch modules Z...8 etc. EPS 12 ATEX 1430 X

Ex eb db IIC T6...T5 Ga/Gb for switch modules Z...5 etc. IECEx EPS 15.0038 X

Ex eb db IIC T6...T5 Ga/Gb for switch modules Z...7 etc. EPS 22 UKEX 1261 X

For type designations or details see page 23.



Hermetically sealed version

### Trimod Besta Level Switches for use in intrinsically safe installations

Level switches with proximity switches acc. to NAMUR (type range I.. and IE9.. etc.) or micro switches with gold plated contacts (type range B) are for connection to intrinsically safe circuits and approved, depending on national regulations, for Zone 1, floats in Zone 0.



For intrinsically safe installation

#### Protection classifications:

Ex ia IIC T6...T1 Ga/Gb for switch modules I...8, IE9...8 etc. EPS 12 ATEX 1430 X

Ex ia IIC T6...T1 Ga/Gb for switch modules I...5, IE9...5 etc. IECEx EPS 15.0038 X

Ex ia IIC T6...T1 Ga/Gb for switch modules I...7, IE9...7 etc. EPS 22 UKEX 1261 X

Ex ia IIC T6... Ga/Gb for switch modules B...8 etc. EPS 12 ATEX 1430 X

Ex ia IIC T6... Ga/Gb for switch modules B...5 etc. IECEx EPS 15.0038 X

Ex ia IIC T6... Ga/Gb for switch modules B...7 etc. EPS 22 UKEX 1261 X

For type designations or details see pages 20 and 22.

### Pneumatic Trimod Besta Level Switches and Level Controllers

Pneumatic level switches of the type ranges FP and FM are approved for installation in Zone 1, floats in Zone 0. For type designations and details see page 24.



Pneumatic version

### Mode of installation

All Trimod Besta level switches of the Ex-proof range may be side or top mounted.



## Micro- and proximity switches

Additional information to the switch module descriptions on pages 20 to 24.

### Microswitches of the switch module range type A

Electrical data acc. to microswitch manufacturer shown in table 35.

### Microswitches of the switch module range type B

The silver contacts of these microswitches are gold plated and intended for use in low-current circuits. Though the max. rating can be as per table 35, please be aware, that the gold plating will be permanently damaged when used for values greater than applicable for intrinsically safe circuits or high voltage/power applications.

Table 35

Voltage V	Resistive Load A	Tungsten Lamp Load		Inductive Load A
		NC A	NO A	
AC bis 250	5	0.5	0.5	5
DC bis 30	5	1.5	1.0	5
DC bis 50	3	0.8	0.8	2.5
DC bis 75	1	0.6	0.6	0.5
DC bis 125	0.5	0.5	0.5	0.07
DC bis 250	0.25	0.25	0.25	0.03

Only approximate values can be given for the allowable charge of gold contacts. These must be reduced under unfavourable impedance conditions. The product of current and voltage should not exceed 0.12 VA. The current should move at  $\leq 300$  mA and voltage at  $\leq 30$  V. For alternating currents these values must be interpreted as maximum values.

### Microswitches of the switch module range type B...8, B...5, B...7

Electrical data acc. to Type-examination acc. to ATEX, IECEx and UKCA Ex.

Gold plated contacts

max. 30 VDC, max. 300 mA, max. 0.12 VA

Li  $\approx 0$   $\mu$ H, Ci  $\approx 0$  nF

### Microswitches of the switch module range type Z...8, Z...5, Z...7

Electrical data acc. to Type-examination acc. to ATEX, IECEx and UKCA Ex.

250 VDC, 0.25 A

250 VAC, 5 A

125 VDC, 0.5 A

75 VDC, 1 A

50 VDC, 3 A

30 VDC, 5 A

### Inductive proximity switches acc. to NAMUR/EN 60947-5-6

The switch modules of the type ranges I and IE9 are especially suitable for applications in hazardous areas\*. The switching element, an inductive proximity sensor (Pepperl+Fuchs) contains only the oscillator. The signal is processed by a remote mounted relay amplifier unit as shown in the connection diagram.

\*(ATEX, IECEx and UKCA Ex)

#### Connection diagram:

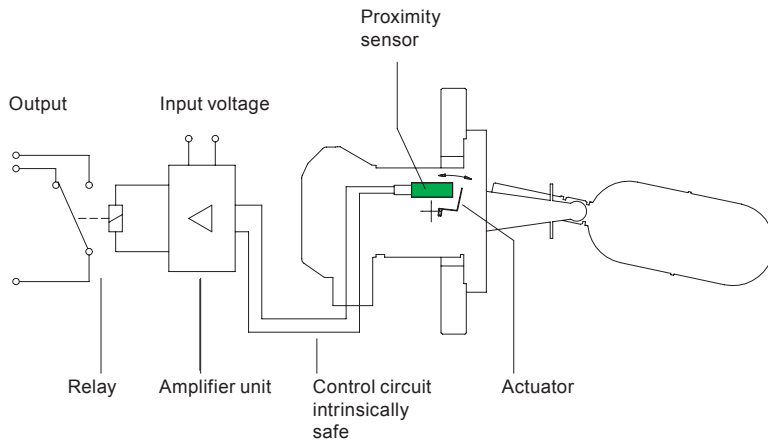

#### Electrical data of inductive proximity switches

Nominal voltage UN	8,2 VDC ±5%
Operating voltage UB	5 to 25 VDC
Current consumption	
sensor uncovered	≥ 2,2 mA
sensor covered	≤ 1 mA
Control line: resistance	≤ 50 Ω

#### Special self checking failsafe features

If the switch is connected for maximum current/voltage in the non alarm state the circuit can be monitored constantly for line and/or instrument failure to initiate operation of a safety shutdown.

The sensor circuit of the switch modules IE9, INE9, and IIE9, are also self checking and approved for safety circuits (TÜV tested). With these sensors, automatic switching to the alarm state in the event of component failure is guaranteed. When specifying a safety circuit, approved amplifiers and transistor relays must be incorporated.

For use in hazardous areas the following data should be observed for Trimod Besta level switches with inductive proximity sensors:

Type I, IN, II:	$U_{max.}$ 16 VDC	$Li \leq 50 \mu H$	$Ci \leq 45 nF$
Type IE9, INE9, IIE9:	$U_{max.}$ 16 VDC	$Li \leq 150 \mu H$	$Ci \leq 50 nF$

# Trimod<sup>B</sup>Besta

## Trimod<sup>B</sup>Besta



Level switches with electric, electronic and pneumatic switch elements. Numerous shipbuilding register certificates and explosion proof approvals.

### Bachofen AG

Ackerstrasse 42  
CH-8610 Uster  
Switzerland  
Phone +41 44 944 11 11  
Fax +41 44 944 12 33  
info@trimodbesta.com  
www.trimodbesta.com

### Homepage

Find your local sales and service partner under  
www.trimodbesta.com

### Quality Management

The Bachofen quality management system acc. to  
ISO 9001 was established in 1994.

### Registered Trade Marks

Trimod and Besta are registered trade marks of  
Bachofen AG, Switzerland.

Your Trimod Besta level switch distributor:

--